

Q.A. DEPT.

**POWERBOSS®**

## OTTER™ SWEEPER/SCRUBBER

TSS/65E • CSS/65E  
Electric Powered Models

## OPERATION, MAINTENANCE, TROUBLESHOOTING & PARTS

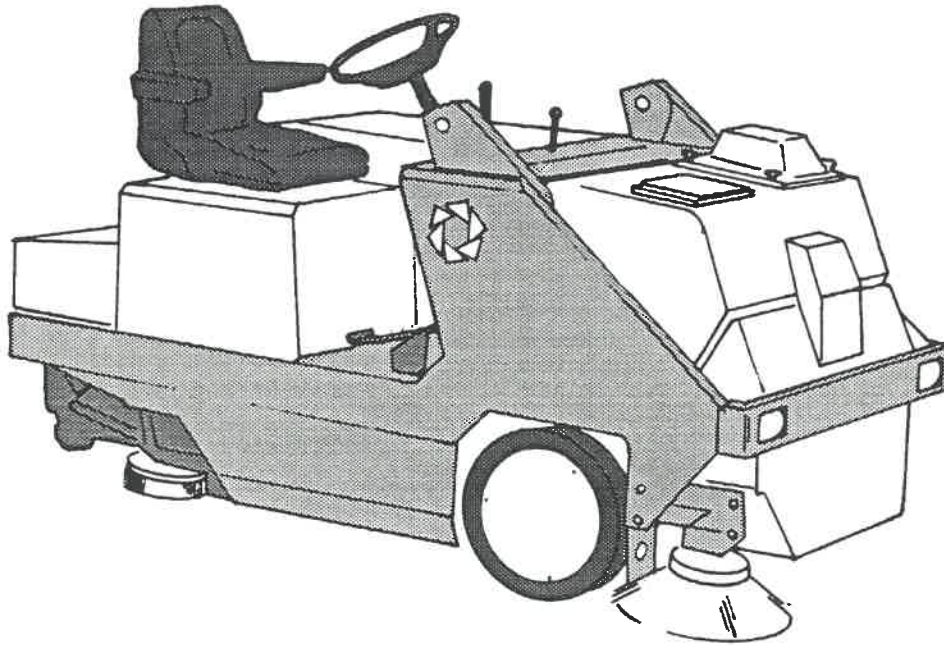

**AAR POWERBOSS** 

Anderson & Taylor Streets / P.O. Box 1227  
Aberdeen, North Carolina 28315 U.S.A.  
(910) 944-2167 / FAX: (910) 944-7409

**FEBRUARY '94**

*All information contained in this manual is current at the time of printing. However, due to constant updates and improvements we reserve the right to make changes at any time without notice.*

**©Copyright 1994, AAR POWERBOSS**

*All rights reserved. This manual may not be copied or reproduced in any form, without the written permission of AAR PowerBoss.*

## TABLE OF CONTENTS

What You Will Find in This Manual.....7

### SAFETY

Safety Symbols .....12  
Safety Decals .....13  
Basic PowerBoss® Safety .....15

### INTRODUCTION

Introducing PowerBoss® Sweeper/Scrubbers .....20  
Special Features .....21

### SPECIFICATIONS

TSS/65E .....24

### COMPONENT DESCRIPTIONS

The Electrical System .....28  
The Lubrication System .....29  
The Hydraulics System .....29  
The Vacuum System .....30  
Sweep Components .....30  
Hoppers .....31  
Steering, Brakes, & Tires .....31

## TABLE OF CONTENTS (Cont.)

### OPERATION

Basic Operating Controls .....	34
Sweeping Controls .....	35
Scrubbing Controls .....	36
Debris Hopper Dump Controls .....	39
Operating Procedures .....	40
Pre-Operation Checks .....	40
Starting .....	40
Slowing and Stopping .....	41
Operating on Grades .....	41
Sweeping .....	41
Emptying the Hopper .....	42
Transporting the Machine .....	43

### MAINTENANCE

Introduction .....	47
Planned Maintenance Chart .....	49
Electrical System .....	54
Electrical Schematic .....	52
Battery Cleaning .....	54
Battery Replacement .....	55
Fuses .....	55
Fuse Replacement .....	55
Hydraulics System .....	58
Filling the Fluid Reservoir .....	58
Hydraulic Fluid Viscosity Specifications .....	58
Changing the Hydraulic Fluid Filter .....	59
Adjusting Machine Speed .....	59
Sweep Components .....	60
Broom Door Flap Inspection .....	60
Broom Door Flap Replacement and Adjustment .....	61
Main Broom Height Adjustment Test .....	61
Main Broom Height Adjustment .....	62
Main Broom Taper Adjustment .....	63
Side Broom Adjustment Inspection .....	64
Side Broom Height (Wear) Adjustment .....	65
Side Broom Lift Cable Adjustment .....	65
Main Broom Replacement .....	66
Side Broom Replacement .....	67

## TABLE OF CONTENTS (Cont.)

Scrub & Water Pick-Up Components .....	68
Scrub Brush Replacement .....	68
Adjusting The Scrubhead .....	69
Scrubhead Gauge Adjustment .....	69
Checking & Adjusting the Main Squeegee Flare .....	70
Turning or Replacing the Main Squeegee Rubber .....	71
Main Squeegee Tool Removal .....	71
Main Squeegee Tool Installation .....	72
Inner Squeegee Replacement .....	72
Auto Squeegee Lift Mechanism .....	72
Hoppers .....	73
High Dump Hopper Removal and Replacement .....	73
Filter Removal .....	74
Filter Cleaning .....	75
Filter Replacement .....	75
Hopper Floor Clearance and Dump Adjustments .....	76
Hopper Vacuum Gasket Mount Adjustments .....	77
Hopper Flap Replacement .....	78
Hopper/Frame Seal Replacement .....	79
Steering .....	80
Parking Brake .....	81
Parking Brake Adjustment .....	81
Tires .....	82
Changing Solid Tires .....	82
Miscellaneous Adjustments .....	83

### TROUBLESHOOTING

Basic Machine Operating Problems .....	86
Sweeping Problems .....	88
Scrubbing Problems .....	90
Squeegee Problems .....	91
Hydraulic System Problems .....	92

INDEX .....	95
-------------	----

## TABLE OF CONTENTS (Cont.)

**PARTS** *(Found in Separate Parts Section)*

Main Broom Group .....	P-2
Steering Group .....	P-6
Impeller Group .....	P-8
Gasket Mount Assembly .....	P-10
Directional Control Group .....	P-12
Potentiometer Mounting Group .....	P-14
Hopper Group .....	P-16
Front Wheel Group .....	P-20
Brake Group .....	P-22
Auxiliary Group .....	P-24
Lift Arm Group .....	P-26
Solution Delivery Tank Group .....	P-28
Operator's Console Group .....	P-30
Side Broom Group .....	P-32
Side Broom Cable Group .....	P-34
Frame Group .....	P-36
Clip / Seat Group .....	P-38
Solution Pick-Up (Vacuum) Group .....	P-40
Floor Pan Group .....	P-42
Broom Door Group .....	P-44
Recovery Tank Group .....	P-46
Top / External Components .....	P-46
Internal / Clean-Out Components .....	P-48
Control Box Group .....	P-50
Scrubhead Group .....	P-52
Squeegee Group .....	P-54
Front Bumper Group .....	P-58
Hydraulic System Group .....	P-60
Miscellaneous Group .....	P-62
Decal Group .....	P-64
<b>PARTS INDEX</b> .....	<b>P-67</b>

## WHAT YOU WILL FIND IN THIS MANUAL

<b>Safety</b>	The Safety Section provides information and rules for the safe operation and maintenance of the sweeper/scrubber.
<b>Introduction</b>	The Introduction Section lists the PowerBoss Otter Sweeper/Scrubber models and summarizes special features which they possess.
<b>Specifications</b>	The Specifications Section lists key specifications of each model indicating capacities, capabilities, and other basic information.
<b>Component Descriptions</b>	The Component Description Section provides a brief summary of each component or system, including specific descriptions where applicable.
<b>Operation</b>	The Operation Section explains the basic controls and accessory controls on PowerBoss Otter Sweeper/Scrubbers and instructions for operation.
<b>Maintenance</b>	The Maintenance Section contains planned maintenance charts and service instructions for required maintenance tasks.
<b>Troubleshooting</b>	The Troubleshooting Section contains a troubleshooting chart to assist you in identifying and correcting problems which may occur during the operation of your equipment.
<b>Parts</b>	The Parts Section contains parts lists, exploded views, and/or photographs of standard machine components.
<b>Miscellaneous</b>	The Miscellaneous Section contains additional information on machine components.

# TSS/65E

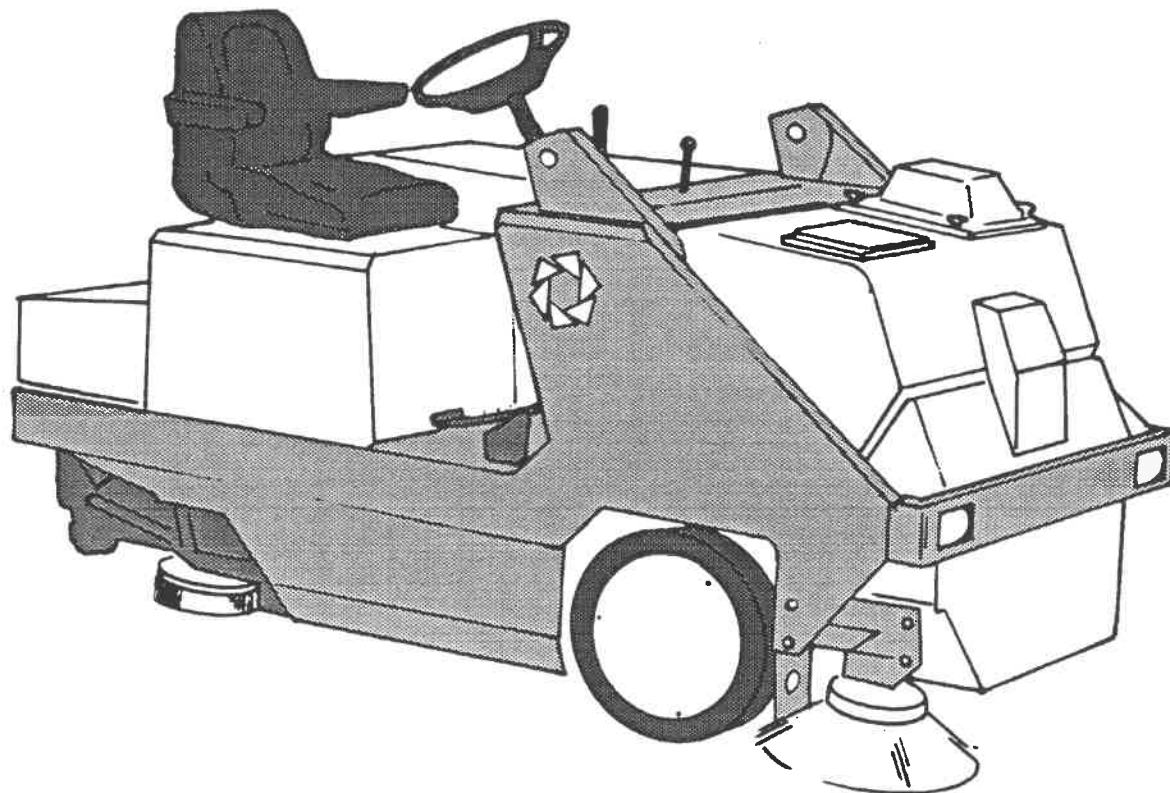

## FEATURES

1. Dust Control Filter (50 Sq. Ft.)
2. Electric Filter Shaker
3. One-Piece Unitized Steel Frame
4. Hydraulics Protection Package
5. Dual Performance Sweep Mode
6. Quick-Change Floating 36" Main Broom
7. Retractable Quick-Change Side Broom
8. Multi-Level Hopper Dumping
9. Built-In Dust PreFiltering
10. Wet Sweep By-Pass Standard
11. Instant Forward & Reverse using one Pedal
12. Excellent Maneuverability due to Compact Size & Rear Wheel Steering
13. Emergency "Kill" Switch Standard
14. Squeegee Vacuum Timer Delay Standard
15. Quiet Operation



## **OTTER Electric Sweeper/Scrubber (LIMITED) PRODUCT WARRANTY**

AAR PowerBoss warrants that the PowerBoss Otter Electric Sweeper/Scrubber will be free from defects in material and workmanship for a period of 24 months or 1,250 operating hours from date of installation, whichever comes first. Written notice of any claimed defect must be given to AAR within the warranty period and within thirty (30) days after such defect is discovered. Liability under this warranty is limited to either replacing or repairing, at AAR's election, any part or parts deemed defective after examination by AAR or an Authorized Service Representative. The PowerBoss machine or any of its parts returned by customer to AAR or an Authorized Service Representative via prepaid transportation and which is found to be defective, will be repaired or replaced and returned to customer via prepaid surface transportation within the Continental U.S. On the other hand, should a part be found not defective, inspection and handling charges may be charged to the customer by AAR or an Authorized Service Representative.

For one hundred eighty (180) days from date of installation, AAR will provide repair labor, at no charge, solely through an Authorized Service Representative. Thereafter, labor will be charged.

This warranty does not extend to the PowerBoss machine, or its parts, that have been subject to misuse, accident or improper handling, installation, maintenance or application, nor does it extend to PowerBoss machine and/or parts which have been repaired or altered outside AAR's plant or the facility of Authorized Service Representative.

This warranty does not apply to routine wearable parts of the PowerBoss machine such as brushes, flaps, filters, seals, points, plugs, hoses or similar items. Moreover, this warranty does not extend to the PowerBoss machine or part replaced or repaired under this warranty.

Only replacement parts supplied by AAR are warranted for 30 days after installation.

The warranty for optional batteries shall be limited to the warranty extended to AAR by the supplier.

**THE WARRANTY SET FORTH HEREIN IS IN LIEU OF AND EXCLUDES ANY AND ALL OTHER WARRANTIES, EXPRESS OR IMPLIED, ARISING BY OPERATION OF LAW OR OTHERWISE, INCLUDING, BUT NOT LIMITED TO, ANY IMPLIED WARRANTY OF MERCHANTABILITY OR FITNESS FOR A PARTICULAR PURPOSE, AND CUSTOMER WAIVES ANY OBLIGATION OR LIABILITY OF AAR ARISING IN TORT OR STRICT LIABILITY IN TORT, OR FOR LOSS OR USE, REVENUE OR PROFIT WITH RESPECT TO PowerBoss MACHINE AND/OR PARTS FOR ANY LIABILITY OF CUSTOMER TO ANY THIRD PARTY, OR FOR OTHER DIRECT, INCIDENTAL OR CONSEQUENTIAL DAMAGES.**

(February 1994)



## **SAFETY SPECIFICATIONS**

Safety Symbols .....	12
Safety Decals .....	13
Basic PowerBoss® Safety .....	15

## SAFETY SYMBOLS

Five symbols are used throughout this manual to emphasize various levels of safety information. These symbols and the meaning of each are listed below.



**DANGER:** To warn of immediate hazards which will result in severe personal injury or death.



**WARNING:** To warn of hazards or unsafe practices which could result in severe personal injury or death.



**CAUTION:** To warn of hazards or unsafe practices which could result in minor personal injury.



**ATTENTION!** To warn of practices which could result in extensive equipment damage.

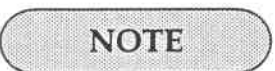

**NOTE:** To direct your attention to important equipment information or special instructions for preventing damage to equipment.

Symbols at the top of the list are the strongest warnings. However, all symbols represent important information which should be observed to protect you and others from harm and injury, and to prevent damage to equipment.

## SAFETY DECALS

Decals directly attached to various parts of the sweeper/scrubber are highly visible safety reminders which should be read and observed. Make sure the decals are replaced if they become illegible or damaged. The decal below is located in the driver's compartment. Other safety decals on your machine appear on the next page.

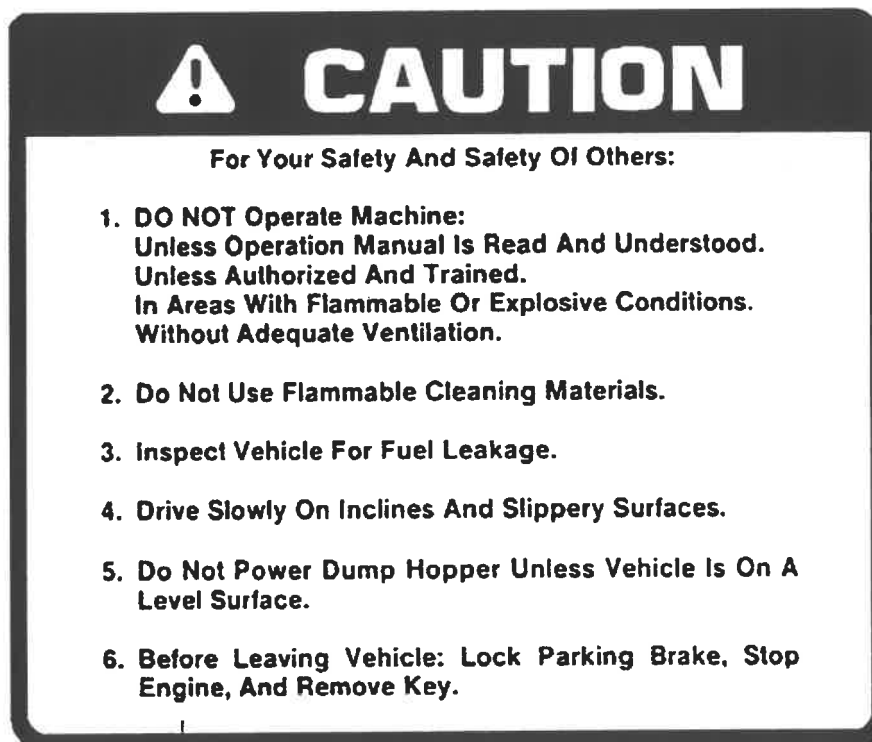

**Part Number 301854**

Located at the Impeller:



Located on the high dump hopper:



Located on the shroud of the radiator:

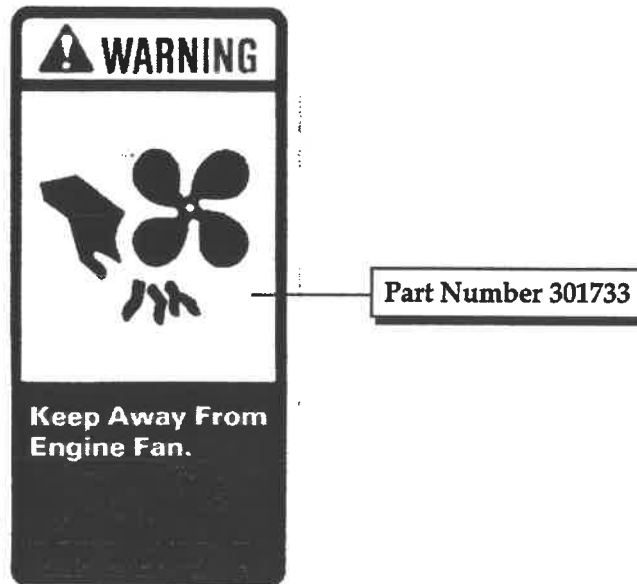

## BASIC PowerBoss® SAFETY

PowerBoss sweeper/scrubbers should never be operated unless: 1. the operator is trained and authorized to operate the equipment and, 2. the equipment is free of malfunctions. Malfunctioning equipment should be removed from service.

### DANGER

1. Keep cigarettes, matches, and all other flame sources away from the sweeper/scrubber. Lead acid batteries are dangerous due to the highly explosive hydrogen gas they emit.

### WARNING

1. Before turning the machine on, make sure that:
  - You are securely seated in the operator's seat.
  - The parking brake is locked.
  - The directional control pedal is in neutral.
  - Hydraulic controls are in OFF position.
2. During operation:
  - Keep your hands and body clear of moving parts, especially when the hopper or lift arms are partially or fully raised.
  - Make sure others in the area stay clear of the equipment and moving parts.
  - Never attempt to dump debris from a dock or mezzanine. Dump from ground level only.
  - When adding cleaning solution, wear safety glasses to prevent possible eye injury.
3. When leaving the sweeper/scrubber unattended:
  - Place the controls in OFF position.
  - Set the parking brake.

## 4. During cleaning and maintenance:

- Always stop the machine and set the parking brake before servicing.
- Never use detergents or cleansers that are flammable or combustible.
- Do not attempt any impeller adjustment unless you have shut off the machine. Never place your hands near the intake hoses or inlet when the machine is running.
- Always engage the safety arm before getting under the hopper. Do not rely on the hydraulic cylinder to keep the hopper raised.

## 5. When servicing or repairing:

- Work in a properly ventilated area, do not smoke, or allow an open flame near the battery. Wear safety glasses.
- Never bypass safety components unless you are testing them.
- Never bypass the fuses, except when testing them (and always reconnect them after testing).
- Always use a piece of paper to test for hydraulic leaks. Personal injury may occur if any part of your body comes in contact with hydraulic fluid forced through a small hole at a high rate of pressure.

## 6. Replace any defective safety components before operating the sweeper/scrubber.

 CAUTION

1. Do not drive with the hopper in the raised position except the few feet necessary to position the hopper over the dumpster or receptacle. Driving with the hopper raised reduces visibility and creates conditions for striking overhead objects, throwing the machine off-balance, and other hazards.
2. Travel slowly on grades.
3. Place a block or chock behind the wheels when parking on inclines.
4. Use special care when traveling on wet surfaces.



5. Observe all proper procedures for operation and maintenance of the sweeper/scrubber, as outlined in this manual.
6. Remain alert at all times to people and equipment in and around your area of operation.

**ATTENTION!**

1. Never push or tow a machine faster than specified.



# INTRODUCTION

Introducing PowerBoss® Sweeper/Scrubbers .....20  
Special Features .....21

## INTRODUCING PowerBoss® SWEEPER/SCRUBBERS

PowerBoss® Sweeper/Scrubbers combine two separate functions in one unit: sweeping and scrubbing. The *sweeping system* using a main broom, a side broom (optional on some models) and an application designed air system cleans surfaces thoroughly and efficiently without creating a dust problem. The side broom creates a wider sweeping path by pushing dirt and debris into the path of the main broom. The main broom then throws all dirt and debris in its path into the hopper. The *scrubbing system* takes water (with soap) from the solution tank and puts it on the floor where the scrub brushes do the cleaning. Then the vacuum system, with the help of the squeegees, picks up the water and puts it into the recovery tank leaving the floor virtually dry.

The two functions, sweeping and scrubbing, can be used individually or in combination such as: sweeping, scrubbing, double-scrubbing or sweeping/scrubbing. This makes the PowerBoss® the most efficient, economical, and versatile system available.

This manual contains information required for the operation and maintenance of the following PowerBoss® sweeper/scrubbers:

TSS/65E

---

### WARRANTY

See LIMITED PRODUCT WARRANTY at the front of this manual for complete warranty details.

---

## SPECIAL FEATURES

You will enjoy all of the following features:

- rugged one-piece unitized frame
- high and effective direct-throw sweeping
- high capacity hoppers with dust control
- rear wheel drive/steering for exceptional maneuverability
- quick-release side broom for quick removal and change
- floating brooms for uneven surfaces



# SPECIFICATIONS

TSS/65E.....24

## TSS/65E

Power	36-Volt Electric System. 550 AmpHours.
Frame	Unitized steel frame with 1.5-inch (38 mm) X 5-inch (127 mm) box section reinforcement.
Drives	Direct Drive of rear wheel through gearbox by 2.0 HP electric motor with solid state speed control. Variable speed to 6 mph (10 kmh). Main broom and vacuum are belt-driven.
Steering	Standard automotive recirculating ball-type through rear wheel.
Turning Radius	Left Hand - 78.19 inches (1984 mm) Right Hand - 91.5 inches (2322 mm) "U" Turn - 111 inches (2816 mm)
Sweep Path	50" (1269 mm) Sweep Path Including Side Brush
Sweep Coverage	132,000 Sq. Ft. (12,263 m <sup>2</sup> ) Per Hour based on a 50-inch Path at 6 MPH (9.66 kmh) with 6-inch (152 mm) overlap. At typical sweeping speed of 4 mph (6 kmh) with 6-inch (152 mm) overlap, covers up to 88,000 Sq. Ft. (8,175 m <sup>2</sup> ) per hour.
Sweeping Brooms	Main Broom: 14-inch (355 mm) diameter, 36-inch (914 mm) length. Cylindrical, one-piece plastic core disposable runs at constant RPM. Five minute broom change. Raised and lowered from operator compartment. Floats for uneven surfaces. Adjustable for pressure and wear.  Side Broom: 21-inch dia. (533 mm) rotary, one-piece disposable. Quick-change in seconds. No tools required. Bumper protected. Features retractable housing that swings away from obstructions. Adjustment for pressure, wear, and angle.
Vacuum System	Fully-enclosed, positive-sealed, reusable panel filter. 50 Sq. Ft. (4.65 m <sup>2</sup> ) of filtering area. Filter cleaned with standard electric shaker motor. High-volume, low-pressure 9-inch (228 mm) dia. impeller provides constant air flow. Wet-sweep Bypass feature is standard.
Debris Hopper	10 Cu. Ft. (0.252 m <sup>3</sup> ) holds up to 500 lbs. (227 kg) multi-level high dump up to 60-inches (1523 mm). Features Wet-Sweep By-Pass as standard item.
Scrub Path	42-inch (1066 mm) scrub path. 50-inch (1269 mm) scrub path with optional side scrub.



## TSS/65E (CONT.)

Scrubbing Coverage	67,000 Sq. Ft. per hour based on 42-inch scrub path at 4 mph with 4-inch overlap. At typical scrubbing speed of 4 mph with 4-inch overlap, covers up to 81,000 Sq. Ft. per hour (with optional side scrub brush).
Scrubbing Brushes	Three rotary 14-inch (355 mm) OD quick-change brushes are electrically-driven.
Solution Tank	50-gallon (189 L) capacity stainless steel with Easy Fill™ automatic water shutoff system.
Recovery Tank	50-gallon (189 L) capacity stainless steel with AutoFlush™ cleanout system.
Vacuum Pick-Up	Two 3-stage 5.7-inch dia. (145 mm) 36-volt DC double ball bearing vacuum motors provide water pick-up through rear squeegee.
Squeegee	One 44.75-inch (1136 mm) U-shaped squeegee with quick-change rubber.
Squeegee Assembly	May be removed from machine in minutes. No tools required. Squeegee automatically lifts in reverse.
Controls/Accessories	Operator controls all functions of sweeping, scrubbing and debris disposal while seated. Foot pedal travel brake. Hand-activated emergency/parking brake. Head- and tail-lights. Horn button.
Instruments	Battery condition and hour meter, Scrubhead down pressure gauge. Recovery tank full light. Emergency switch.
Tires	Front - Two 18-inch (457 mm) OD Industrial Solid (Non-Marking Optional) Rear - One 16-inch (406 mm) OD Industrial Solid (Non-Marking Optional)
Weight	Net - 2,120 Lbs. (964 kg). Shipping - 2,370 Lbs. (1077 kg). Shipping - 3,600 Lbs. (1636 kg) with batteries. All approximate.
Dimensions	Length - 100-inches (2538 mm). Width - 48-inches (1218 mm). Height - 57-inches (1447 mm). 79.5-inches (2018 mm) with overhead guard. <u>Battery Compartment:</u> Length - 22.25-inches (564 mm). 565 mm Width - 13.56-inches (344 mm). Height - 23.12-inches (586 mm) maximum.

## CSS/65E

Power	36-Volt Electric System. 550 AmpHours.
Frame	Unitized steel frame with 1.5-inch (38 mm) X 5-inch (127 mm) box section reinforcement.
Drives	Direct Drive of rear wheel through gearbox by 2.0 HP electric motor with solid state speed control. Variable speed to 6 mph (10 kmh). Main broom is belt-driven.
Steering	Standard automotive recirculating ball-type through rear wheel.
Turning Radius	Left Hand - 78.19 inches (1984 mm) Right Hand - 91.5 inches (2322 mm) "U" Turn - 111 inches (2816 mm)
Sweep Path	50" (1269 mm) Sweep Path Including optional Side Brush
Sweep Coverage	132,000 Sq. Ft. (12,263 m <sup>2</sup> ) Per Hour based on a 50-inch Path at 6 MPH (9.66 kmh) with 6-inch (152 mm) overlap. At typical sweeping speed of 4 mph (6 kmh) with 6-inch (152 mm) overlap, covers up to 88,000 Sq. Ft. (8,175 m <sup>2</sup> ) per hour. (Includes optional Side Brush.)
Sweeping Brooms	Main Broom: 14-inch (355 mm) diameter, 36-inch (914 mm) length. Cylindrical, one-piece plastic core disposable runs at constant RPM. Five minute broom change. Raised and lowered from operator compartment. Floats for uneven surfaces. Adjustable for pressure and wear.  Side Broom (Optional): 21-inch dia. (533 mm) rotary, one-piece disposable. Quick-change in seconds. No tools required. Bumper protected. Features retractable housing that swings away from obstructions. Adjustment for pressure, wear, and angle.
Debris Hopper	10 Cu. Ft. (0.252 m <sup>3</sup> ) holds up to 500 lbs. (227 kg) multi-level high dump up to 60-inches (1523 mm).
Scrub Path	42-inch (1066 mm) scrub path. 50-inch (1269 mm) scrub path with optional side scrub.
Scrubbing Coverage	67,000 Sq. Ft. per hour based on 42-inch scrub path at 4 mph with 4-inch overlap. At typical scrubbing speed of 4 mph with 4-inch overlap, covers up to 81,000 Sq. Ft. per hour (with optional side scrub brush).

## CSS/65E (CONT.)

Scrubbing Brushes	Three rotary 14-inch (355 mm) OD quick-change brushes are electrically-driven.
Solution Tank	50-gallon (189 L) capacity stainless steel with Easy Fill™ automatic water shutoff system.
Recovery Tank	50-gallon (189 L) capacity stainless steel with AutoFlush™ cleanout system.
Vacuum Pick-Up	Two 3-stage 5.7-inch dia. (145 mm) 36-volt DC double ball bearing vacuum motors provide water pick-up through rear squeegee.
Squeegee	One 44.75-inch (1136 mm) U-shaped squeegee with quick-change rubber.
Squeegee Assembly	May be removed from machine in minutes. No tools required. Squeegee automatically lifts in reverse.
Controls/ Accessories	Operator controls all functions of sweeping, scrubbing and debris disposal while seated. Foot pedal travel brake. Hand-activated emergency/parking brake. Head- and tail-lights. Horn button.
Instruments	Battery condition and hour meter, Scrubhead down pressure gauge. Recovery tank full light. Emergency switch.
Tires	Front - Two 18-inch (457 mm) OD Industrial Solid (Non-Marking Optional) Rear - One 16-inch (406 mm) OD Industrial Solid (Non-Marking Optional)
Weight	Net - 2,120 Lbs. (964 kg). Shipping - 2,370 Lbs. (1077 kg). Shipping - 3,600 Lbs. (1636 kg) with batteries. All approximate.
Dimensions	Length - 100-inches (2538 mm). Width - 48-inches (1218 mm). Height - 57-inches (1447 mm). 79.5-inches (2018 mm) with overhead guard. <u>Battery Compartment:</u> Length - 22.25-inches (564 mm). Width - 13.56-inches (344 mm). Height - 23.12-inches (586 mm) maximum.

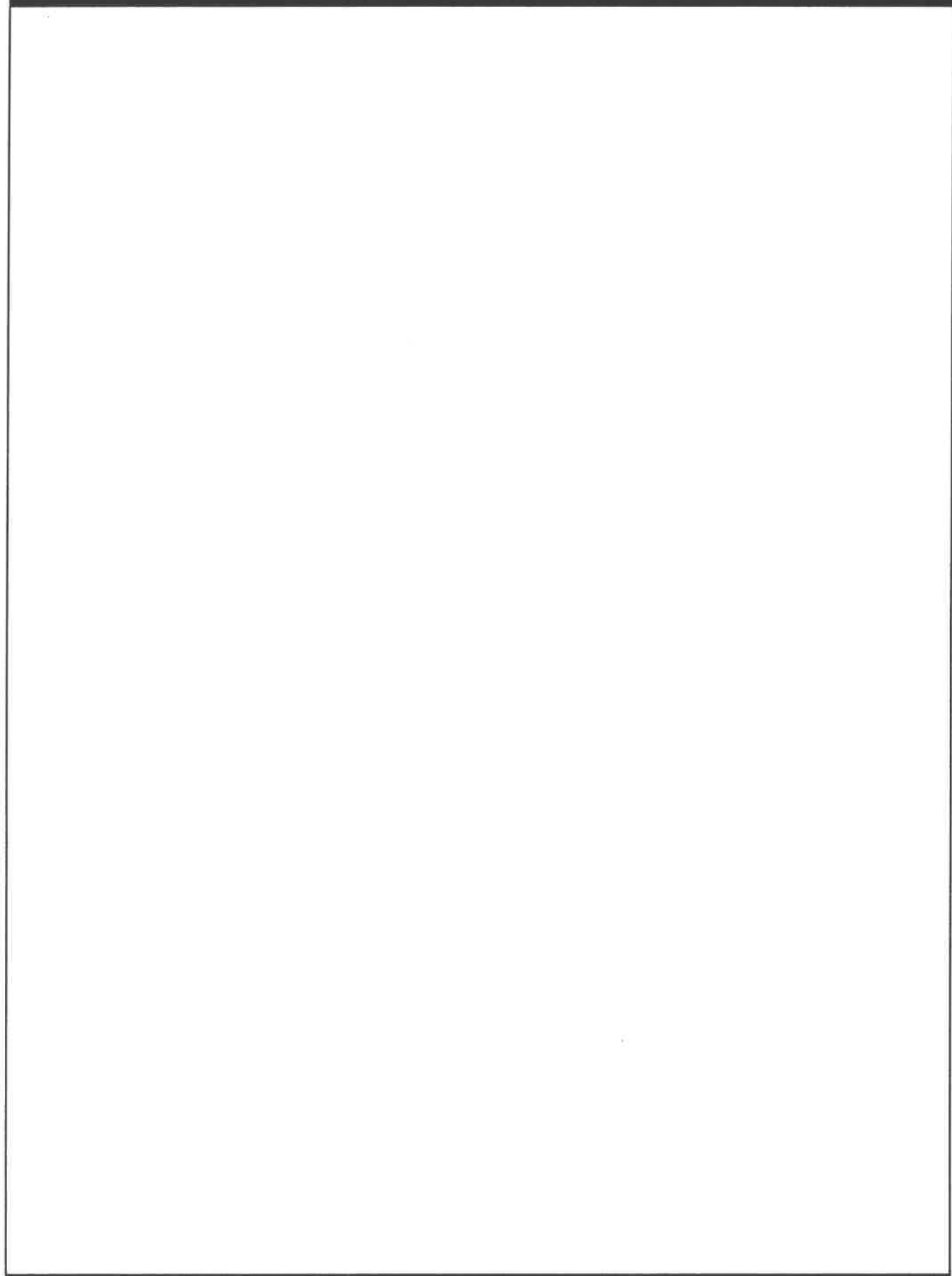

## COMPONENT DESCRIPTIONS

Electrical System.....	28
Lubrication System .....	29
Hydraulics Systems .....	29
Vacuum System .....	30
Sweep Components .....	30
Hoppers .....	31
Steering, Brakes, and Tires .....	31

**THE ELECTRICAL  
SYSTEM****Fuses**

There are four 20 Amp fuses located to the left of the driver. Below is a chart showing locations of the fuses and their purpose as viewed left to right from the driver's seat.

1. Battery/Hour Meter, Auxiliary Motor
2. Scrubhead, Side Scrub (Option)
3. Safety "Kill" Switch
4. Squeegee

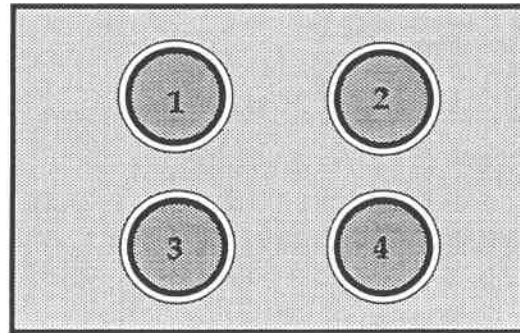

**THE LUBRICATION SYSTEM** Grease fittings supply lubrication to:

- steering cylinder pivot points
- steering fork assembly
- pillow blocks supporting dump arms
- scrub deck tubes

For detailed information on lubrication requirements and the lubrication points and grease fittings, refer to the Maintenance section of this manual.

**THE HYDRAULICS SYSTEM**

**THE VACUUM SYSTEM**

The vacuum system consists of a belt driven 9-inch impeller connected to a damper type hopper vacuum shut-off.

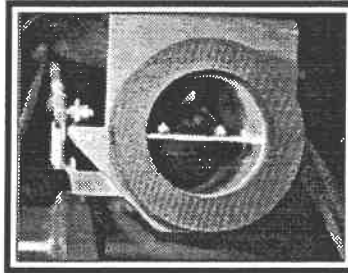

**Hopper Shut-Off**  
(A.K.A. Gasket Mount Assembly)

**Filter and Shaker**

TSS/65E models have one fully enclosed, positive sealed, quick-change filter providing 50 sq. ft. (4.65 m<sup>2</sup>) of filtering area and one electric shaker for cleaning the filter. The Wet-Sweep Bypass feature is standard.

**SWEEP COMPONENTS****Main Broom**

The 36 inch (914 mm) main broom has the following features:

- one-piece, cylindrical, and disposable
- runs at constant RPM
- can be changed in less than five minutes
- is raised and lowered from operator compartment
- floats for uneven surfaces
- adjusts for pressure and wear
- belt-driven

**Side Broom**

A 21 inch, rotary, one-piece disposable side broom can be quick changed in seconds without tools, is bumper protected, and adjustable for angle, pressure, and wear.

**Skirts**

Skirts on the bottom of each side panel and at the back of the broom chamber help contain the dust inside the sweeping and vacuuming compartment.

**Capabilities**

Sweep paths and coverages are listed by model in the Specifications section of this manual.



**HOPPERS**

**TSS** TSS hoppers are constructed of 12 GA steel and come with a multi-level high dump.

All machines are equipped with a frame seal and side seals to contain dust and fine debris within the hopper.

**STEERING, BRAKES,  
AND TIRES**

**Steering** Standard automotive recirculating ball-type steering through the rear wheel.

**Brakes** All models have drum brakes with hand lever activated mechanical parking brake.

**Tires** Front - Two 18-inch solid  
Rear - One 16-inch solid



## OPERATION

Basic Operating Controls .....	34
Sweeping Controls .....	35
Scrubbing Controls .....	36
Debris Hopper Dump Controls .....	39
Operating Procedures .....	40
Pre-Operation Checks .....	40
Starting .....	40
Slowing and Stopping .....	41
Operating on Grades .....	41
Sweeping .....	41
Emptying the Hopper .....	42
Transporting the Machine .....	43

## **BASIC OPERATING CONTROLS**

- IGNITION SWITCH** The one position keyswitch is used to turn the machine's electric power on and off.
- HORN** The horn is activated by pressing the horn button located to the left of the driver.
- BATTERY LEVEL GAUGE** The battery gauge indicates the amount of charge remaining in the batteries.
- HOUR METER** The hour meter records the number of hours the machine has been operated, providing a helpful guide for performing routine maintenance tasks.
- EMERGENCY SHUTOFF** The emergency "kill" switch (or shutoff) is located on the console and shuts off all electrical current in the event of a shortage.
- DIRECTIONAL CONTROL PEDAL** The directional control pedal controls the speed and direction of the machine. It is also used for slowing the machine or stopping.
- To propel the machine forward, apply pressure to the front of the pedal, increasing pressure to increase speed.
  - To propel the machine backward, apply pressure to the rear of the pedal.
  - To slow or stop the machine, move foot pedal into neutral.
- The sweeper/scrubber is equipped with a speed limiter, a stop under the pedal which can be raised to reduce maximum speed.
- PARKING BRAKE** The drum brakes on the two front wheels are operated by pressing on the brake pedal. The parking brake is rod-actuated. To engage the parking brake pull upward on the hand brake lever located on the left side of the front wall of the operator's compartment.

## SWEEPING CONTROLS

### MAIN BROOM HANDLE

The main broom handle to the immediate left of the driver raises and lowers the main broom. For normal sweeping, position the handle at LOWER on the handle slot.

#### NOTE

- *When not sweeping, position and lock handle at RAISE position on the handle slot.*

### SIDE BROOM HANDLE

The side broom handle to the immediate left of the driver raises and lowers the side broom.

#### NOTE

- *When not sweeping, the side broom should remain in the RAISE position.*

#### NOTE

- *To lower the side broom, position the handle at LOWER in the handle slot.*

The side broom, also known as the curb broom, is used to widen the sweep path and to clean close to walls and other obstructions.

## SCRUBBING CONTROLS

### FILLING THE SOLUTION TANK

To fill the solution tank follow these steps:

1. Drive to the solution filling site.
2. Park the machine on a level area and lock the parking brake.
3. Make sure the solution delivery valve is closed.
4. Open the top door of the machine and fill the top tank with cleaning water solution.
5. When the tank is full, close the top door.

 CAUTION

*Never use detergents or cleaners that are flammable or combustible. Always wear safety glasses when using chemicals of any kind.*

### MAIN SCRUB BRUSHES

To operate the main scrub brushes follow these steps:

1. Lower the scrubheads to the floor with the scrubhead switch. Obtain the correct pressure for the floor conditions by noting pressure shown on the scrubhead position gauge. The scrubheads are raised with the same switch.

NOTE

*For normal scrubbing, the main broom and side broom remain in the raised position.*

NOTE

*To sweep simultaneously, lower the brooms at this time. Even though the brooms and brushes are both rotating, each is lowered independently.*

2. Lower the squeegee and lock it in the down position with the squeegee switch. The squeegee can also be raised with the same switch.
3. Start the flow of solution to the floor. To dispense solution push the solution delivery lever forward. To stop the flow of solution pull the lever back to the OFF position. The amount of solution dispensed increases as the lever is moved forward, varying the flow rate between 0 gallons per minute (in the OFF position) and 3 gallons per minute (in the SOLUTION ON FULL position).
4. Drive forward slowly.

## SCRUBBING CONTROLS *(Continued)*

 CAUTION

*Use care when driving on wet surfaces.*

 CAUTION

*Always travel slowly on grades.*

### DOUBLE SCRUBBING

For double scrubbing proceed as follows:

1. Follow the procedures on the previous page for scrubbing *without* lowering the squeegee to the floor.
2. Make multiple passes over the same area of floor as conditions dictate.
3. Lower and lock the squeegee in the down position with the squeegee switch for the final pass. The squeegee can be raised with the same switch.

### DRAINING THE RECOVERY TANK

Follow these steps to drain the recovery tank:

1. Park the machine on a level surface with the left rear of machine beside the drain site.
2. Engage the parking brake.
3. Turn off the machine.
4. Pull hose from driver's side (under floor pan).
5. Pull out the drain hose for maximum reach.
6. Place the drain hose at the floor drain opening, grate or on the ground.
7. Loosen and remove the drain plug.
8. Drain the tank completely and reinstall the plug.
9. Reposition the drain hose in its storage area.

## SCRUBBING CONTROLS *(Continued)*

### CLEANING THE RECOVERY TANK

To clean the recovery tank proceed as follows:

**NOTE**

*The recovery tank should be cleaned after every shift.*

1. Engage the parking brake.
2. Shut off the machine.
3. Remove the drain hose and position it over the floor drain opening.
4. Spray the recovery tank with clean water, flushing all sludge out the drain tube.
5. Reinstall the drain plug.
6. Reposition the hose in the storage area beneath the floor pan.



## DEBRIS HOPPER CONTROLS

### HOPPER FILTER SHAKER BUTTON

The hopper holds all debris picked up when sweeping. The filter shaker button is used to activate the filter shaker prior to dumping or as needed during sweeping operation. It is located to the left of the driver and beside the horn button.

To shake filter:

1. Bring the machine to a complete stop.
2. Turn broom OFF.
3. Press and hold the filter shaker button for 20 to 30 seconds.
4. Turn broom ON and resume sweeping.

This button should only be pushed when the machine is stopped, the hopper vacuum is shut off, and the hopper is raised approximately 4-inches above the ground.

 CAUTION

*Do not leave the hopper in RAISE position for an extended period of time.*

## OPERATING PROCEDURES

### PRE-OPERATION CHECKS

Prior to starting the machine, check the following:

1. Battery water level
2. Hydraulic fluid level
3. Brakes, steering, and directional controls
4. The floor beneath the machine for signs of fluid leaks

Fluid levels should be correct. Brakes, steering, and directional controls should be functioning properly. Hoses, lines, and tanks should be free of damage and leaks.

### STARTING



**WARNING** *Before starting the machine, seat yourself in the operator's seat and make sure the parking brake is locked.*

1. Make sure the directional control pedal is in neutral position.
2. Make sure the parking brake is released.
3. **Battery-powered:** Turn ignition key to START position.
4. Move the machine forward or backward as follows:
  - **Forward:** Apply pressure to the front of the directional control pedal, increasing pressure to increase speed.
  - **Reverse:** Apply pressure to the rear of the pedal, increasing pressure to increase speed.



**High Dump  
Models**

1. Drive the machine to the dumping area.
2. Use the directional control pedal to position the machine so that the space between the machine and the container or dumpster is adequate to raise the hopper.

**NOTE**

**Note:** *Broom controls must be in OFF positions.*

3. Close the hopper dump door.
4. Pull back lever to RAISE position and hold until the bottom of the hopper is high enough to clear the top of the container.
5. Move over container and open hopper dump door.

**WARNING**

*Never place your hands or other body parts near the lift arms when the hopper is operating.*

**CAUTION**

*It is unsafe to travel an extended distance with the hopper raised. Travel only the distance necessary to position the hopper.*

6. At this point, shake filters for 20 - 30 seconds.
7. After hopper empties, push Lever 2 forward to RETURN position until the hopper rotates and stops.
8. Slowly back machine away from dumpster approximately 5 feet.
9. Push lever forward to the LOWER position until the hopper stops.

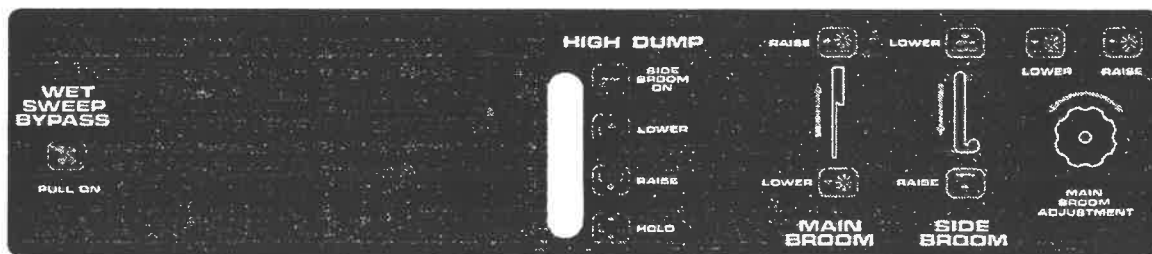

**Controls That Are Located On The Lintel  
(the control panel in front of the steering wheel)**

**TRANSPORTING THE MACHINE****Loading**

1. Position the machine on the transport vehicle or trailer and apply the parking brake.
2. Tie the machine down using the tie down holes in the frame in front of both front wheels and in the rear of the frame. (There are a total of 4 tie-down areas.)

**NOTE**

**Note:** Attach the tie downs to the frame only.

**Pushing  
or Towing**

1. Push the machine from the front or rear using bumpers only.
2. Before towing, check to see if parking brake is released.



## MAINTENANCE

Introduction .....	47
Planned Maintenance Chart .....	49
Electrical System .....	54
Electrical Schematic .....	52
Battery Cleaning .....	54
Battery Replacement .....	55
Fuses .....	55
Fuse Replacement .....	55
Lubrication .....	56
Lubrication Points .....	56
Hydraulics System .....	58
Filling the Fluid Reservoir .....	58
Hydraulic Fluid Viscosity Specifications .....	58
Changing the Hydraulic Fluid Filter .....	59
Adjusting Machine Speed .....	59
Sweep Components .....	60
Broom Door Flap Inspection .....	60
Broom Door Flap Replacement and Adjustment .....	61
Main Broom Height Adjustment Test .....	61
Main Broom Height Adjustment .....	62
Main Broom Taper Adjustment .....	63
Side Broom Adjustment Inspection .....	64
Side Broom Height (Wear) Adjustment .....	65
Side Broom Lift Cable Adjustment .....	65
Main Broom Replacement .....	66
Side Broom Replacement .....	67

## TABLE OF CONTENTS (Continued)

Scrub & Water Pick-Up Components .....	68
Scrub Brush Replacement .....	68
Adjusting the Scrubhead .....	69
Scrubhead Gauge Adjustment .....	69
Checking & Adjusting the Main Squeegee Flare .....	70
Turning or Replacing the Main Squeegee Rubber .....	71
Main Squeegee Tool Removal.....	71
Main Squeegee Tool Installation .....	72
Inner Squeegee Replacement .....	72
Auto Squeegee Lift Mechanism .....	72
Hoppers .....	73
High Dump Hopper Removal and Replacement .....	73
Filter Removal .....	74
Filter Cleaning .....	75
Filter Replacement .....	75
Hopper Floor Clearance and Dump Adjustments .....	76
Hopper Vacuum Gasket Mount Adjustments .....	77
Hopper Flap Replacement .....	78
Hopper/Frame Seal Replacement .....	79
Steering .....	80
Parking Brake .....	81
Parking Brake Adjustment .....	81
Tires .....	82
Changing Solid Tires .....	82
Miscellaneous Adjustments .....	83



## INTRODUCTION

Regular maintenance on your sweeper/scrubber results in better cleaning, faster cleaning, and a prolonged service life for the equipment and components. This section contains the following information to help you give your sweeper/scrubber the maintenance attention it requires:

- A Planned Maintenance Chart
- Service Instructions for Required Maintenance Tasks

Because it is extremely important to your safety, you will see the following **WARNING** repeated throughout this section:



*Never attempt to perform any service on the equipment or components until the machine is OFF, the parking brake is LOCKED, and the wheels are CHOCKED.*



## PLANNED MAINTENANCE CHART

FREQUENCY (IN HOURS)					SERVICE (BY MAINTENANCE AREA)
DAILY	50	100	200	500	
X					<p><b>ELECTRICAL SYSTEM</b></p> <p>Check electrolyte level in battery cells and fill as needed.</p>
X					<p>Clean battery top.</p>
X					<p><b>HYDRAULIC SYSTEM</b></p> <p>Check hydraulic fluid level and fill as needed.</p>
				X	<p>Replace breather cap filter element.</p>
				X	<p>Replace hydraulic fluid and filter.</p>
X					<p><b>SWEEPING COMPONENTS</b></p> <p>Inspect brooms for wear and remove strings and debris from bristles and drive assembly.</p>
	X				<p>Inspect broom skirts for wear and adjust or replace as needed.</p>
	X				<p>Rotate main broom end-to-end.</p>
	X				<p>Perform main broom adjustment test and adjust as needed.</p>
X					<p>Inspect the side broom for wear and adjust as needed.</p> <p><i>Replace main and side brooms as needed.</i></p> <p style="text-align: center;"><i>Main Broom - Bristles are 1" in length. Side Broom - Bristles are 3" in length.</i></p>

## PLANNED MAINTENANCE CHART

FREQUENCY (IN HOURS)					SERVICE (BY MAINTENANCE AREA)
DAILY	50	100	200	500	
X					<p><b>HOPPER</b></p> <p>Check hopper filter and clean or replace as needed.</p>
	X				<p>Check hopper clearance from floor and adjust as needed.</p>
X					<p>Inspect the hopper flaps for wear or damage and replace as needed.</p>
		X			<p>Inspect hopper side and frame seals for wear or damage. Adjust or replace as needed.</p>
				X	<p><b>STEERING</b></p> <p>Lubricate steering linkage rod ends.</p>
				X	<p>Lubricate steering fork assembly.</p>
	X				<p>Check for leaks.</p>
	X				<p><b>PARKING BRAKE</b></p> <p>Check for proper functioning and adjust as needed.</p>
X					<p><b>TANKS</b></p> <p>Check squeegee tool and vacuum hose for clogs.</p>

**BATTERY REPLACEMENT**

1. Unplug the battery connector.
2. Remove the battery.
3. Install new battery.
4. Plug in battery connector.

**FUSES**

If a fuse blows, it must be replaced with a fuse of the same amperage. (The fuses are located on the rear cover to the left of the driver.)

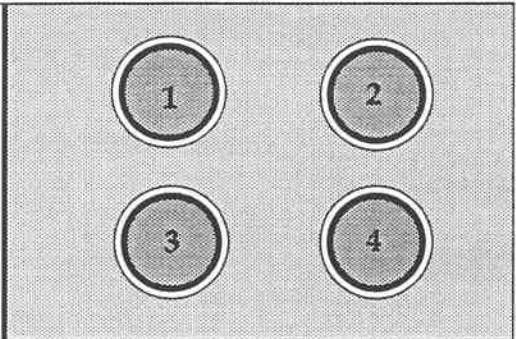
FUSE USAGE	
<ol style="list-style-type: none"><li>1. Battery/Hour Meter, Auxiliary Motor</li><li>2. Scrubhead, Side Scrub (Option)</li><li>3. Safety "Kill" Switch</li><li>4. Squeegee</li></ol>	

**FUSE REPLACEMENT**

1. Remove the blown fuse by turning the fuse holder cap counter-clockwise.
2. Insert the correct amperage fuse into the fuse holder cap.
3. Install the fuse holder cap by turning the cap clockwise.

## LUBRICATION POINTS

<b>Lubrication</b>	<b>Type of Lubrication</b>	<b>Frequency (In Hours)</b>
Linkage (1 fitting)	Grease	100
Hood Latches & Hinges	Oil	200
Scrubhead Lift Tubes	Grease	Daily

# HYDRAULIC SCHEMATIC TSS/65E

## HYDRAULICS SYSTEM

To keep the hydraulics system in good condition, the following maintenance is required:

- Check the dipstick of the hydraulic fluid reservoir daily and fill the reservoir as needed. *Note: The dipstick for the hydraulic reservoir is located under the rear cover or clip.*

### SERVICE INSTRUCTIONS

**⚠ WARNING**

*Never attempt to perform any service on the equipment or components until the machine is OFF, the parking brake is LOCKED, and the wheels are CHOCKED.*

**⚠ WARNING**

*Never service hydraulics without wearing safety glasses.*

### FILLING THE FLUID RESERVOIR

**NOTE:** *The reservoir is located inside the machine and is accessible by tilting the rear cover or clip backward.*

1. When the machine is cool and the hopper is in the lowered position, remove the dipstick. Fluid level should be between the high and low marks on dipstick.

**NOTE:** *DO NOT OVERFILL! DO NOT USE TRANSMISSION FLUID INSTEAD OF HYDRAULIC FLUID. AAR PowerBoss recommends Chevron Dello 400.*

2. If the fluid level is not acceptable, add hydraulic fluid.

### HYDRAULIC FLUID VISCOSITY SPECIFICATIONS

SUS @ 100° F 510-560

SUS @ 210° F 78-84



**CHANGING THE HYDRAULIC FLUID FILTER**

1. Engage the parking brake.
2. Unscrew the oil filter cartridge from the mount and discard.
3. Apply a thin coating of fluid to the seal of a new filter element.
4. Thread onto the mount and hand tighten.
5. Tighten an additional one-half turn beyond hand tight.

**NOTE:** *Do not overtighten.*

6. Start the machine, turn on any motor, shut it off, then check for leakage.

**ADJUSTING MACHINE SPEED**

To limit the speed of the machine, simply reposition the speed limiter, a bolt underneath the directional control pedal which can be moved in or out. Be sure that the directional control pedal contacts the speed limiter bolt.

## SWEEP COMPONENTS

The following maintenance is required to assure maximum cleaning efficiency and service life of sweep components:

- Inspect brooms daily for wear. Remove any strings, wires, or other debris entangled in the bristles or drive assembly.
- After every 50 hours of operation:
  - Inspect broom skirts for wear and replace as needed.
  - Rotate the main broom end-to-end.
  - Perform the main broom adjustment test and adjust as needed.
  - Inspect the side broom for proper angle and contact and adjust as needed.
- Perform taper adjustment when the main broom adjustment test indicates it is necessary.
- Replace main broom when bristles wear to a length of 1". Replace side broom when bristles wear to a length of 3".

## SERVICE INSTRUCTIONS



*Never attempt to perform any service on the equipment or components until the machine is OFF, the parking brake is LOCKED, and the wheels are CHOCKED.*

### BROOM DOOR FLAP INSPECTION

*NOTE: Perform this inspection when the machine is parked on a level surface.*

1. Turn the machine off and lock the parking brake.
2. Inspect broom door (side panel) flaps for wear and damage. Flap clearance should be 1/8" above the floor.
3. Worn and damaged flaps should be replaced immediately to maintain proper dust control. (See illustration on the next page.)

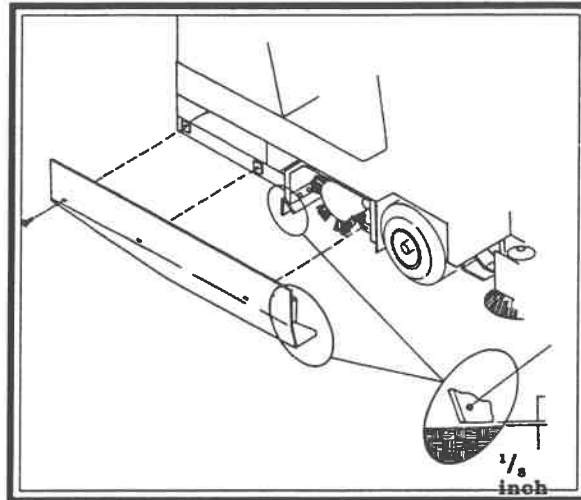

**Broom Door Flap Clearance**

### **BROOM DOOR FLAP REPLACEMENT AND ADJUSTMENT**

The flaps are attached to the side panels by a retainer bar and hex bolts and nuts. To remove the flaps, remove nuts, bolts, and retainer bar. To adjust flaps, loosen nuts and bolts, slide flap up or down as needed. Retighten nuts and bolts.

### **MAIN BROOM HEIGHT ADJUSTMENT TEST**

*NOTE: Perform this adjustment on a flat, smooth test surface.*

1. Drive the machine onto the test surface with the main broom in the RAISE position.
2. Set the parking brake and position the main broom handle in LOWER position.
3. Turn ON the Auxiliary Motor Switch.
4. Allow about 45 seconds for the broom to operate, then turn OFF the broom motor and raise the broom.

*NOTE: Test time will vary according to the test surface used.*

5. Drive the machine clear of the test site.
6. Examine the polished pattern made by the broom on the test area.

*NOTE: A rectangular shape the length of the main broom, 2" wide, indicates the main broom is properly adjusted. A pattern smaller than 2" indicates need for lower adjustment. A pattern wider than 2" indicates a need for higher adjustment. If pattern is tapered from end to end instead of rectangular, see Taper Adjustment on the next page.*

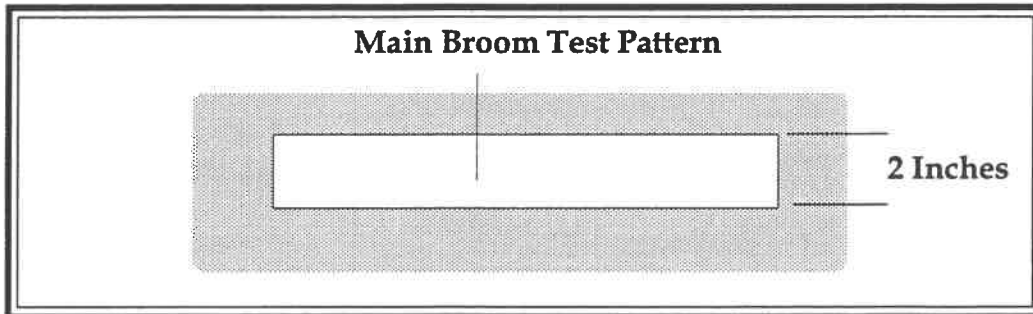

**MAIN BROOM HEIGHT ADJUSTMENT**

1. Turn the machine off and lock the parking brake.
2. Position the main broom lever in the LOWER position.

*NOTE: The adjustment knob is located in the operator's compartment in front of driver's left knee.*

3. Turn the broom adjusting knob clockwise one-eighth turn to free locknut.
4. Turn the locknut counter-clockwise to allow space for adjustment.
5. Make a lower or higher adjustment with the knob as required.
6. Retighten the locknut.
7. Repeat the main broom adjustment test to see that the broom is properly adjusted.

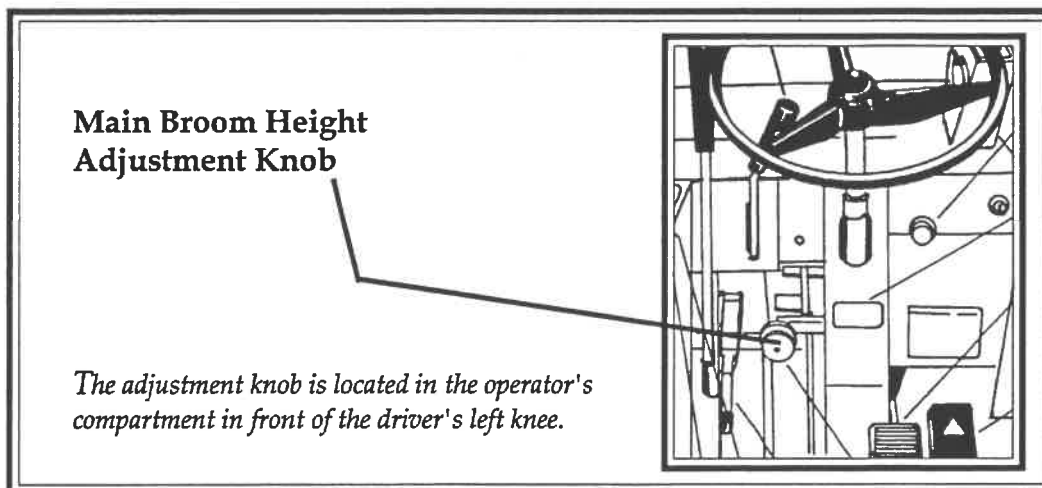

## MAIN BROOM TAPER ADJUSTMENT

**NOTE** *It is not usually necessary to perform this adjustment. However, if the main broom adjustment test shows a pattern that is tapered in length (one end is wider than the other), perform the procedures which follow.*

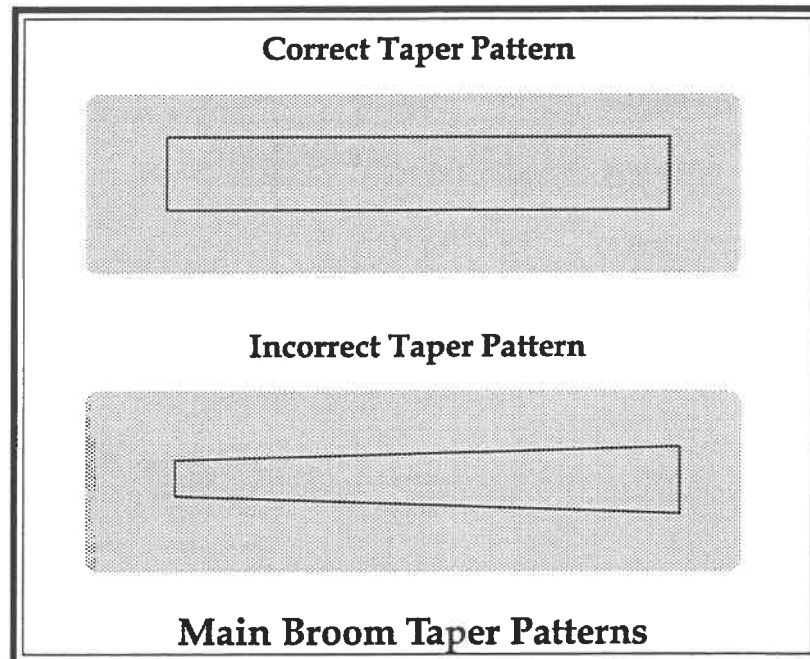

1. Locate the adjusting screws directly beneath the floor pan.
2. Loosen the retaining bolts on the outside of the mounting bracket.
3. Raise or lower the right end of the main broom. (The left end of the broom remains fixed. All adjustments affect the right end of the broom.)
4. After adjustment, tighten retainer bolts.
5. Repeat the main broom adjustment test to see that the broom is properly adjusted.

**SIDE BROOM ADJUSTMENT INSPECTION**

Inspect the side broom for proper angle and contact with the floor. Optimum side broom angle is 6°. Proper contact is achieved when the bristles contact the floor from 3:00 to 10:00 as shown in the drawing below.

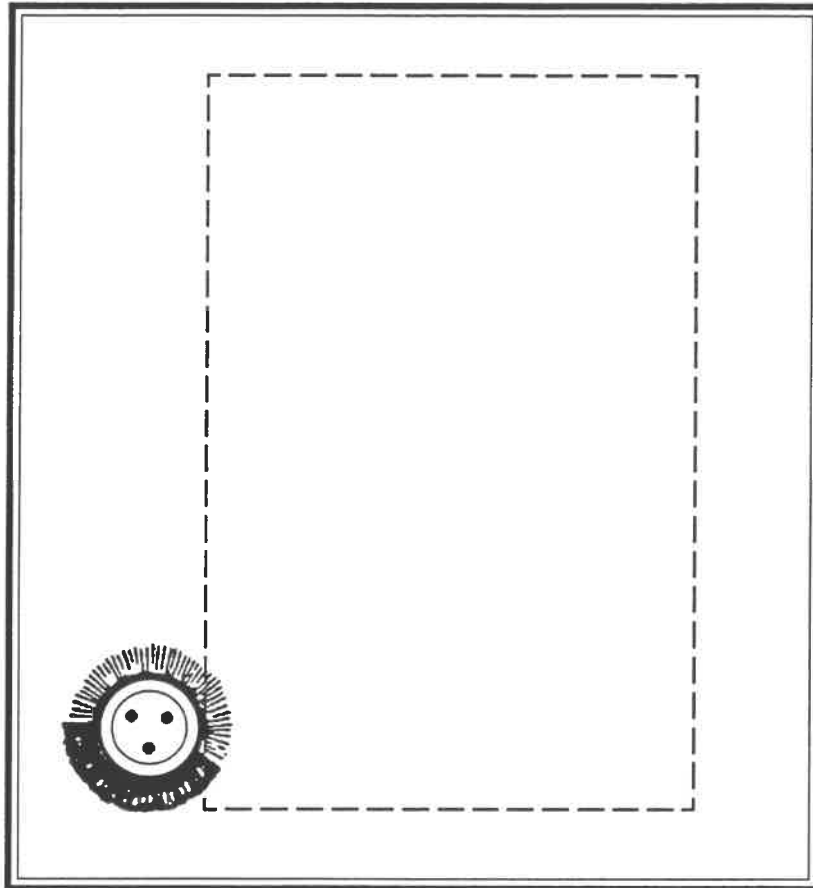

### **SIDE BROOM HEIGHT (WEAR) ADJUSTMENT**

The height of the side broom is adjusted with the use of a stop bolt located at the lower rear of the curb broom arm. As the side broom wears it will be necessary to lower the arm. To lower the side broom, loosen the jam nut on stop bolt. Turn the stop bolt in a counter-clockwise direction, check side broom for proper contact and re-tighten the jam nut.

### **SIDE BROOM LIFT CABLE ADJUSTMENT**

This adjustment is made at the cable clevis attached to the side broom assembly. It controls the height of the side broom in the RAISED position. This adjustment must be made with the hopper fully lowered.

1. Pull the side broom lever into the RAISED position.
2. Loosen the locknut on the threaded rod at the clevis.
3. Turn the threaded rod in or out to set the side broom in the maximum raised position.
4. Secure the cable adjustment by tightening the locknut.

**MAIN BROOM REPLACEMENT (Bristles worn to length of 1 inch)**

1. Turn the machine off and lock the parking brake.
2. Push the main broom control lever to the LOWER position.
3. Remove the right side panel (on side with driver's seat). (This involves removing three bolts.)
4. Using a 3/4" wrench, remove the hex bolt on the main broom idler mount.
5. Pull the main broom idler mount straight out to remove.
6. Grasp the main broom by the plastic drive hub, pull the main broom straight out and clear of the broom chamber.
7. At this point, depending on broom condition, you can either rotate the old broom end-to-end and re-install it or you can install a new broom. In either case, you need to slide the main broom into the broom chamber and align the broom with the metal drive hub located at the far side of the broom chamber.

If a worn broom is being replaced, it may be easier to install the new broom by first adjusting the broom arms up, to better match the position of the drive hub with the hub on the new broom.

8. Once the broom is started onto the drive hubs, rotate the broom counter-clockwise while pushing lightly against the broom.
9. Once the broom is fully engaged, replace the idler hub while aligning the seats in the idler hub with the broom's drive hub ears.
10. Install the retaining bolt into position and tighten with the wrench.
11. Re-install the right side panel.
12. Perform a main broom adjustment test and adjust as needed.

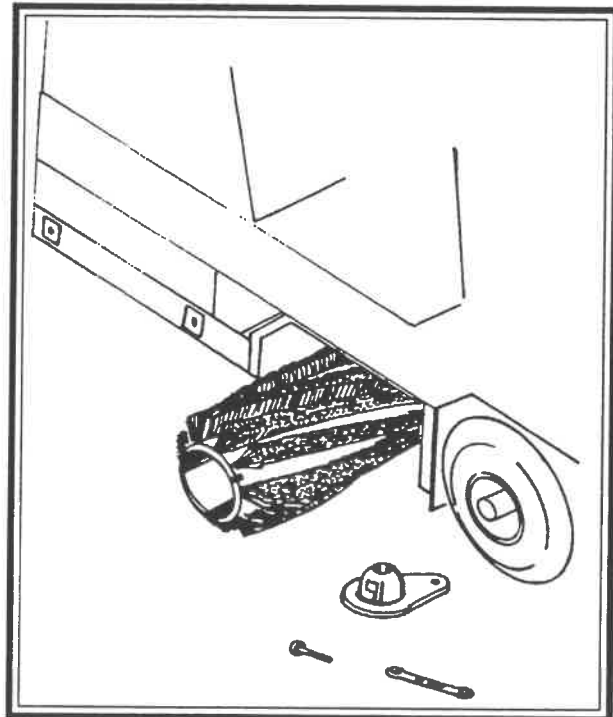



**SIDE BROOM REPLACEMENT (Bristles worn to length of 3 inches)**

**NOTE:** The side broom features a quick release mechanism which enables the operator to remove the brush in seconds.

1. Raise the side broom and lock in RAISE position.
2. Turn the side broom by hand until the brush retainer bar is accessible.
3. Lift the bar and turn the broom clockwise (about one eighth of a turn) until the lock pins in the broom disengage from the drive plate.
4. Install the new broom by positioning the three drive pins into the pilot holes of the drive plate.
5. Lift and rotate the broom until the broom retainer bar springs into the locked position.
6. Check to make sure all three drive pins are properly engaged.

**Side Broom Removal**

1. Lift Brush Retainer
2. Rotate Brush
3. Remove Brush

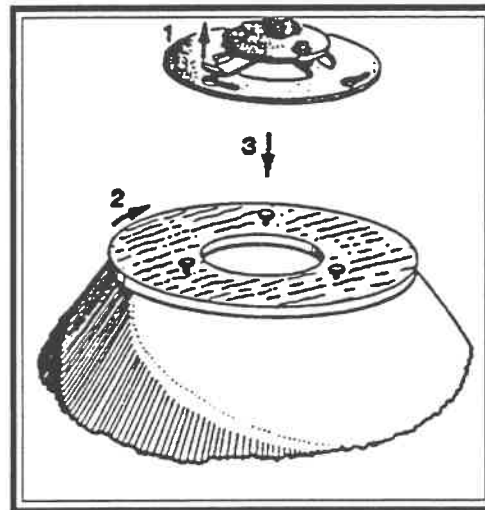

## SCRUB & WATER PICK-UP COMPONENTS

The following maintenance is required to assure maximum cleaning efficiency and service life of scrub & water pick-up components:

- Grease scrubhead lift tubes daily.
- After every 50 hours of operation:
  - Inspect scrub brushes for wear and replace as needed.
  - Check the main squeegee for wear. Turn or replace as needed.
- Inspect squeegee flare daily and adjust as needed.

### SERVICE INSTRUCTIONS



*Never attempt to perform any service on the equipment or components until the machine is OFF, the parking brake is LOCKED, and the wheels are CHOCKED.*

### SCRUB BRUSH REPLACEMENT

The scrub brush features a quick release mechanism which enables the operator to remove the brush in seconds.

*NOTE: Brushes should be replaced when bristles are less than 1/2" long.*

1. Raise the scrubhead.
2. Turn the scrub brush by hand until the brush retainer spring is accessible.
3. Squeeze the spring to release the brush.
4. Install the new brush by lining up the notches with the drive hub.
5. Lift and squeeze the spring until the brush goes into the drive hub.
6. Check to make sure all three brushes are properly engaged.

### **ADJUSTING THE SCRUBHEAD**

The only adjustment necessary is side to side leveling. If you need to make this adjustment, then:

1. Lower brushes on level surface. Run brushes to get a pattern. If one side is light or uneven, then turn off machine and engage emergency shutoff to prevent accidental starting. Engage parking brake.
2. Using the rods that come up through the lift channel, screw the nut in on the opposite side and check pattern again.
3. Repeat Step 2 until you have an even pattern from side to side.

### **SCRUBHEAD GAUGE ADJUSTMENT**

1. Raise the scrubheads to the full "UP" position.
2. Locate the linkage attached to the frame above the scrubheads.
3. Loosen set screw (the bolt running through the arm).
4. Turn the potentiometer shaft until the gauge needle points to the white dot at the left of the gauge.
5. Re-tighten set screw.

*NOTE: A nonfunctional gauge does not prevent the scrubhead from being used.*

**CHECKING & ADJUSTING THE MAIN SQUEEGEE FLARE**

1. Park the machine on a flat surface. Lower squeegee.
2. Turn the machine off and engage the parking brake.
3. Loosen the locking nut on the squeegee caster and screw the caster up until it clears the floor.
4. Locate the squeegee arms on each side of the machine.
5. Loosen the bolt which attaches the upper squeegee arm to the squeegee mount plate on each side.
6. Locate and loosen both nuts on each squeegee adjustment link and back them away from the gussets. The rear squeegee is now free to be aligned with the floor.
7. Check the squeegee rubber to make sure the squeegee makes contact with the floor all the way around. It should stand straight on the floor with *no flare*.
8. At each squeegee mount, turn the two nuts on the adjusting link until the squeegee is raised on the front approximately 1/16".
9. Tighten the nuts on each mount plate. Then tighten the bolt on top of each of the two upper squeegee arms.
10. With the squeegee straight up on the floor (no flare), adjust the caster until it clears the floor by 1/2".
11. Use a 1/2" shim spacer of metal or wood as a feeler gauge for this procedure.
12. Tighten the nut on the caster and move the shim.
13. With the squeegee in the down position, drive the machine forward approximately two feet. Examine the flare in the squeegee rubber to see that it is uniform around the entire parabola. If not, go through Steps 3 to 11.

## TURNING OR REPLACING THE MAIN SQUEEGEE RUBBER

The primary rubber on the main squeegee frame has four different edges that may be used: the front and back lower edge, and the front and back upper edge. When the edge in use becomes worn to the midpoint of thickness, turn the rubber to an unused edge in the order indicated: 1. Front Lower Edge, 2. Opposite Lower Edge, 3. Front Upper Edge, 4. Opposite Upper Edge. In other words, first use the opposite side of the lower front edge, then turn the squeegee upside down to use the front and then the back of the upper edge. Removal and replacement instructions follow. This procedure can be performed with the squeegee tool on or off machine.

*NOTE: Removal and replacement of the main squeegee elements is easier if the squeegee frame is removed from the machine.*

1. Remove the hand knobs from the rear of the squeegee frame.
2. Remove the metal strap, the two back-up strips, and the outer squeegee rubber.
3. Turn the side ends of the squeegee rubber 180°, or turn the rubber upside down, to expose an unused edge. Reposition the rubber on the pins of the squeegee frame.
4. Reposition the first back-up strip using the top holes.
5. Reposition the second back-up strip using the bottom holes.
6. Reposition the metal strap so that the center slot is on the center stud.
7. Install the center knob and tighten it.
8. Place the remainder of the strap and knobs on the studs, working from the center out to the edge.

*NOTE: Replace the back-up strips only if they lose their elasticity.*

## MAIN SQUEEGEE TOOL REMOVAL

All machines are equipped with auto-squeegee lift. To remove the squeegee tool, proceed as follows:

1. Engage parking brake and chock wheels.
2. Put the squeegee switch in the down position and turn the ignition switch off. (This will hold the squeegee in the down position.)
3. Disconnect the vacuum hose from the squeegee.
4. Disconnect the quick-release ball joint from the squeegee.

*(continued on next page)*

5. Locate the squeegee frame supports on each side of the squeegee and remove the hand knobs (one on each side).
6. Lift the supports up off the pins on the squeegee frames and slide the squeegee tool toward the rear of the machine.
7. Go to the back of the machine and pull the squeegee straight back and out.

### **MAIN SQUEEGEE TOOL INSTALLATION**

1. At the back of the machine, push the squeegee forward under the machine.
2. Lift the supports up onto the pins on the squeegee frames.
3. On each side of the squeegee attach the hand knobs (one on each side) to the squeegee frame supports.
4. Put the squeegee switch in the down position and turn the ignition switch off. (This will hold the squeegee in the down position.)
5. Connect the quick-release ball joint to the squeegee.
6. Connect the vacuum hose to the squeegee.

### **INNER SQUEEGEE REPLACEMENT**

The inner squeegee is a component of the rear squeegee. When the squeegee is down, locked, and the rear squeegee rubber is flared, the inner squeegee has become too worn to make proper contact with the floor.

1. Remove the main squeegee tool (see removal instructions).
2. Remove nuts on the front of the inner squeegee frame.
3. Remove the strap and the inner squeegee rubber.
4. Install the new inner squeegee rubber.
5. Position the strap and secure with the nuts.

### **AUTO SQUEEGEE LIFT MECHANISM**

**Bearing Replacement:** If any binding occurs in the lift apparatus, replace the bushings, spacers and dry bearings located on the scrubhead lift assembly as necessary.

## HOPPERS

The following maintenance is required to assure maximum cleaning capacity of hoppers:

- Check hopper filter and clean or replace as needed.
- Check hopper clearance from floor and adjust as needed.
- Inspect hopper flaps daily for wear and damage and replace when needed.

### SERVICE INSTRUCTIONS



*Never attempt to perform any service on the equipment or components until the machine is OFF, the parking brake is LOCKED, and the wheels are CHOCKED.*

### HIGH DUMP HOPPER REMOVAL AND REPLACEMENT

It is not usually necessary to remove or replace the hopper on high dump models. However, if it becomes necessary for maintenance or to install an option, use the following procedure to remove:

1. Park the machine on a level surface and engage the parking brake.
2. Raise the hopper and position the high dump hopper dolly, a platform truck or similar four wheeled cart under the hopper.
3. Set the hopper down on the truck and turn the machine off.
4. Remove three bolts, washers, nuts, and backing plate.
5. Disconnect the wire connections at the right side of the hopper.
6. Roll the hopper away from the machine.

**TO REPLACE:**

1. Position the hopper on the dolly so as to align the mounting holes in the sides of the hopper with the rotation mounts on the arms. Lift arms should be positioned about 1/3 of way up.
2. Start the machine and lift hopper.
3. Drive the truck away from the hopper dolly or cart.
4. Lower hopper.
5. Engage wire connections at right side of hopper.

**FILTER REMOVAL:**

1. Raise the hopper. Engage the safety arm.
2. Release the latch on the hopper cover and raise cover.
3. Disconnect the wire harness leading to the filter shaker motor.
4. Unscrew the two (2) screws (each attached using one conical washer and an isolator) securing the filter retainer bars to the hopper.
5. Remove the shaker motor assembly and filter retainer bars.
6. Lift out the panel filter.



### **FILTER CLEANING**

The dust control filter is a permanent type paper element filter. It may be vacuumed, blown out with compressed air, tapped against the floor, or washed with soap and water.

1. If blown out with compressed air, use 100 psi or less.

*NOTE: The filter may be blown out while installed or removed.*

2. If washed with soap and water, use 40 psi water pressure or less.

*NOTE: Make sure the filter is thoroughly dried while standing on its side before installing in the hopper. Do not install or use a wet filter.*

### **FILTER REPLACEMENT**

1. Insert the panel filter.
2. Install the shaker motor assembly.
3. Install and tighten the four filter retaining screws & isolators.
4. Hook the wire harness to the filter shaker motor.
5. Close the hopper cover and secure the latch.

## HOPPER FLOOR CLEARANCE & DUMP ADJUSTMENTS

In order to perform properly, the hopper must maintain a distance of 3-1/2" from the floor to the rear hopper entrance lip. The front of the hopper should be adjusted so that the front bumper aligns with the hopper frame where the two meet. When properly adjusted, the front edge of the hopper will be 5" to 6" from the floor.

### ADJUSTING MAXIMUM HOPPER DUMP ANGLE

1. Park the machine on a level surface, turn the keyswitch to the OFF position, and engage the parking brake.

**CAUTION**

*Do not rely upon hydraulic cylinders to keep hopper raised for maintenance. Always engage the safety arm before getting under the hopper.*

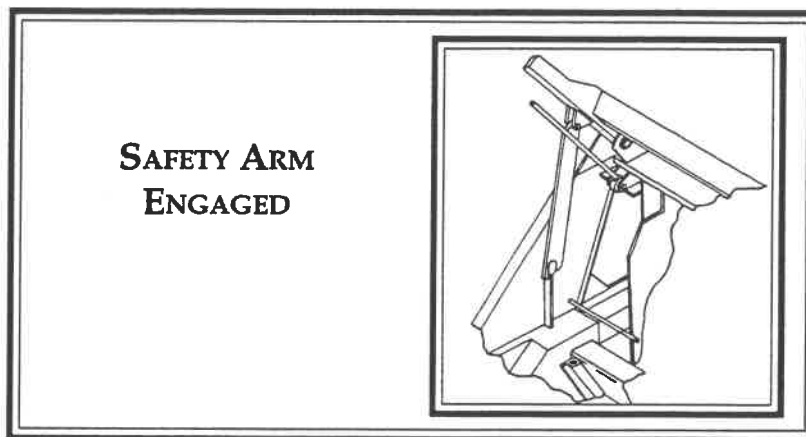

2. Adjust the lift arm stop bolts located on top of the wheel wells as low as possible while still allowing the side broom assembly to clear the lift arms when the hopper is in normal position. Be sure that both lift arms contact the stop bolts at the same time.

*NOTE: This may involve raising and lowering the hopper several times.*

**ADJUSTING MAXIMUM HOPPER DUMP ANGLE (CONT.)**

4. After the 3-1/2" clearance is established, make sure both stops make contact simultaneously. The lower front edge of the hopper should be 5"-6" from the floor. A balanced adjustment of both sets of adjustment bolts is required to correctly adjust the hopper in the lowered position. If the bumper is lower than the frame, after the hopper is correctly adjusted, loosen the bumper attachment bolts and reposition the front bumper.
5. Next, raise the hopper and rotate fully.
6. Turn the machine off.

**⚠ CAUTION**

*Do not rely upon hydraulic cylinders to keep hopper raised for maintenance. Always engage the safety arm before getting under the hopper.*

7. Loosen the locking set screw in the bottom side of the rotation cylinder rod end.
8. Using the hole in the cylinder rod, turn the rod to adjust cylinder extended length to match hopper rotation stops.
9. Tighten the set screw.
10. Remove the safety arm, and lower the hopper.

**HOPPER VACUUM GASKET MOUNT ADJUSTMENT**

1. With hopper in normal position, observe contact between back of hopper and gasket. If complete seal is not maintained, raise high dump hopper.

**⚠ CAUTION**

*Do not rely upon hydraulic cylinders to keep hopper raised for maintenance. Always engage the safety arm before getting under the hopper.*

2. Loosen mounting bolts in gasket mount. Move assembly toward hopper. Tighten bolts. Test and repeat, if necessary.

## HOPPER FLAP REPLACEMENT

Flaps located at the entrance lip of the hopper, and on the sides of the hopper, must be replaced when worn or damaged. The flap panels may be replaced separately.

1. Park the machine on a level surface and engage the parking brake.
2. Raise the hopper.

 CAUTION

*Do not rely upon hydraulic cylinders to keep hopper raised for maintenance. Always engage the safety arm before getting under the hopper.*

3. Turn the keyswitch to OFF.
4. Remove the flap retaining angle and worn or damaged flaps.
5. Install new flaps.
6. Replace the retaining angle.

 CAUTION

*Always wear safety glasses to prevent eye injuries.*

## HOPPER / FRAME SEAL REPLACEMENT

### FRONT FRAME SEAL

The hopper frame seal bolts to the front edge of the frame. Install a new seal by folding it in half to align holes. Doubled edge with holes goes on the bottom. Support the seal straight up while bolting the retainer bar in place. The seal should fall over the retainer bar after installation. Be certain that the seal edges are aligned to prevent twisting of the seal

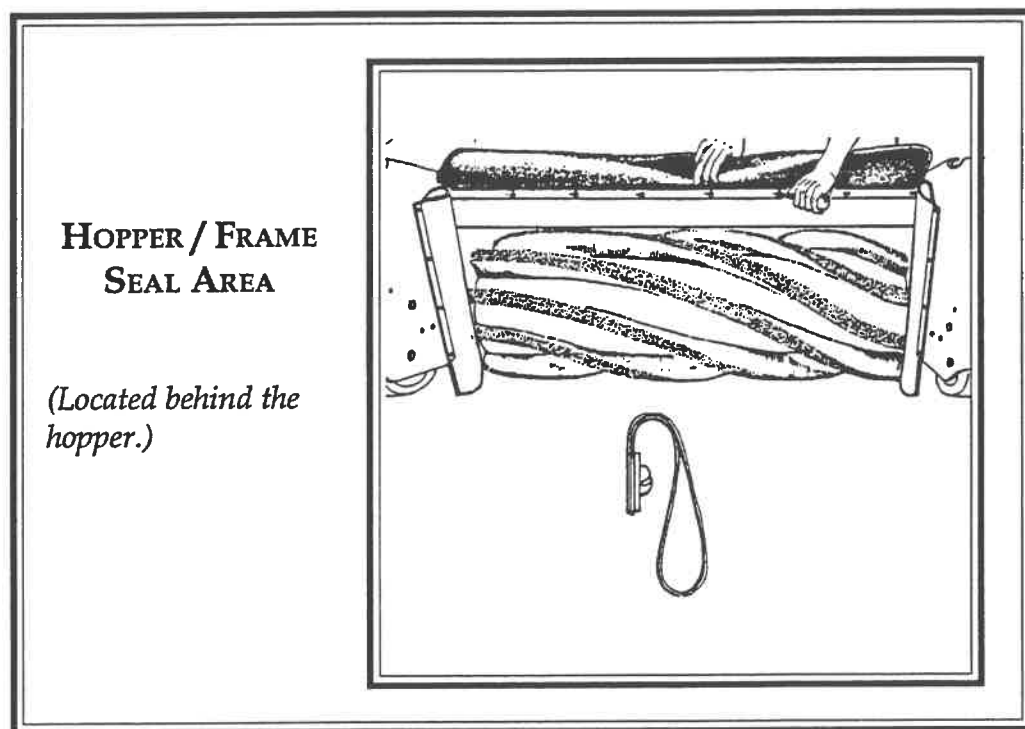

### SIDE FRAME SEAL

The side frame seals should clear the floor by at least 1/8".

If the bottom of a side seal measures 1/2" or more above the floor, readjust it or replace it by removing the bolts on the inside of the frame wheel wells, installing a new seal, and securing it with the bolts. The double edge with the holes goes toward the front.

## STEERING

---

To keep steering mechanisms safe and efficient, perform the following maintenance:

- Lubricate the grease points on the steering linkage and steering fork assembly after every 100 hours of operation.



*Never attempt to perform any service on the equipment or components until the machine is OFF, the parking brake is LOCKED, and the wheels are CHOCKED.*

## PARKING BRAKE

---

Normal adjustment of the parking brake can be accomplished from the operator compartment. Locate the knurled handle on the parking brake lever. Turn the handle clockwise to increase brake tension. *Note: Two or three turns is usually adequate. DO NOT OVERTIGHTEN!!*

---

 CAUTION

*Do not rely upon hydraulic cylinders to keep hopper raised for maintenance. Always engage the safety arm before getting under the hopper.*

### ADJUSTING THE PARKING BRAKE ROD LENGTH

1. Park the machine on a level surface and chock wheels.
2. Place parking brake lever in "OFF" position.
3. Turn knurled handle counter-clockwise as far as possible.
4. Raise hopper and engage safety arm.
5. Locate the rod clevis ends at the brake bar.
6. Disconnect clevis ends from bar.
7. Loosen jam nuts at the base of the clevis.
8. Turn clevis clockwise three or four complete turns.
9. Tighten jam nuts and re-install clevis ends onto bar.
10. Adjust knurled handle on parking brake lever (according to above instructions).

## TIRES

PowerBoss® TSS/65E sweeper/scrubbers use a tire and rim. Tire maintenance requires the following:

- Visually inspect tires daily for wear and damage.

### SERVICE INSTRUCTIONS



*Never attempt to perform any service on the equipment or components until the machine is OFF, the parking brake is LOCKED, and the wheels are CHOCKED.*

### CHANGING SOLID TIRES

*NOTE: The procedures which follow apply to solid tires only.*

1. Remove cover plate from tire by removing the three bolts.
2. Remove tire from vehicle by removing the cotter pin.
3. Remove the tire from the axle plate.
4. Replace with the new tire.
5. Install new cotter pin.
6. Bolt on the cover plate.



## MISCELLANEOUS ADJUSTMENTS

---

- Each machine is equipped with an anti-static chain bolted to the back wall of the broom chamber. This should remain in contact with the floor at all times. Inspect the chain every 200 operating hours. Replace if at least one link does not drag the surface of the floor.
  - Latches and hinges should be inspected after every 200 hours of use. Retighten and oil if necessary.
  - Inspect cables for wear every 200 hours.
- 

## SERVICE INSTRUCTIONS



*Never attempt to perform any service on the equipment or components until the machine is OFF, the parking brake is LOCKED, and the wheels are CHOCKED.*



## TROUBLESHOOTING

Basic Machine Operating Problems .....	86
PowerBoss® moves slowly or does not move .....	86
PowerBoss® creeps in neutral .....	86
No Power .....	87
Vacuum motors will not operate .....	87
Sweeping Problems .....	88
Little or no vacuum in brush compartment .....	88
Loss of dust control .....	88
Sweeper unit leaving debris .....	88
Hopper does not raise or lower .....	89
Hopper does not rotate or rotates too slowly .....	89
Scrubbing Problems .....	90
Scrubhead will not lower .....	90
Scrubhead motors will not turn .....	90
Side Scrub Option will not shift .....	90
Side Scrub Option will not lower .....	90
Squeegee Problems .....	91
Squeegee will not lower .....	91
Squeegee will not raise in reverse .....	91
Hydraulic System Problems .....	92
Hopper lift cylinder failure .....	92
Hydraulic control valve failure .....	92
Hydraulic gear pump failure .....	92
Hydraulic variable displacement pump failure .....	93
Hydraulic system noisy .....	93

## BASIC MACHINE OPERATING PROBLEMS

PROBLEM	CAUSE	SOLUTION
<b>PowerBoss®</b> moves slowly or does not move.	Parking brake is on.	Release brake.
	Directional control pedal jammed, damaged, or not adjusted properly.	Clear jam or adjust linkage.
	Tires skidding from contact with oil or grease.	Clean tires or drive through a solvent absorbing substance.
	Wheels jammed.	Clear jam.
	Fuse blown.	Replace.
	Drive contactor defective.	Replace.
	Wires 8,9 & 10 at foot pedal may be loose.	Connect wires.
	Loose potentiometer switch wire(s).	Connect wires.
<b>PowerBoss®</b> creeps in neutral.	Loose drive controller wire(s).	Connect wires.
	Worn or loose drive controller cables.	Replace if worn. Tighten if loose.
	Directional control pedal return spring is out of adjustment.	Perform the adjustment procedure.

## BASIC MACHINE OPERATING PROBLEMS (CONT.)

PROBLEM	CAUSE	SOLUTION
No power.	Battery cable connections worn.	Replace cables.
	Batteries not charged.	Charge batteries.
	Loose wires at ignition switch or potentiometer switch.	Connect wires.
	Fuse blown.	Replace.
Vacuum motors will not operate.	Fuse blown.	Replace.
	Loose or defective timer (beside vacuum box tube).	Connect, if loose. Replace, if defective.
	Loose or defective control box contactor.	Connect, if loose. Replace, if defective.

### SWEEPING PROBLEMS

PROBLEM	CAUSE	SOLUTION
Little or no vacuum in broom compartment.	Filter clogged.	Clean filter.
	Leak or clog in hose from impeller.	Repair leaks; clear obstructions or replace hose.
	Impeller failure.	Check and repair.
Loss of dust control.	Debris in hose or impeller inlet.	Clean.
	Broom skirts or seals worn.	Replace.
	Skirt clearance from floor exceeds 1/8".	Adjust clearance.
	Dust control filters clogged.	Clean filters.
	Filter seals worn or missing.	Replace.
Sweeper unit leaving debris.	Poor seal with vacuum gasket at hopper.	Visually check and adjust, if necessary.
	Hopper full.	Dump hopper.
	Broom(s) out of adjustment.	Adjust.
	Broom bristles worn.	Check broom for wear and adjustment.
	Poor performance of broom drive mechanism.	Check for jam in broom chamber.
Broom lift arms hung up with debris.	Clear out debris.	

### SWEEPING PROBLEMS (CONT.)

PROBLEM	CAUSE	SOLUTION
Sweeper unit leaving debris. (Cont. from previous page)	Hopper flaps damaged or missing.	Replace or adjust clearance.
	Hopper out of adjustment.	Check hopper clearance.
	Dust control filter clogged.	Clean filter.
Hopper does not raise or lower.	Hydraulics system problem: - control valve - gear pump - lift cylinder	See Hydraulics Systems Problems in this section.
	Hopper arms binding.	Lubricate or adjust arm linkage.
Hopper does not rotate or rotates too slowly.	Hopper load too heavy.	Dump more frequently.
	Hydraulics system problem: - control valve - gear pump - lift cylinder	See Hydraulics System Problems in this section.

## SCRUBBING PROBLEMS

PROBLEM	CAUSE	SOLUTION
Scrubhead will not lower.	Fuse blown.	Replace.
	Defective scrubhead switch.	Replace.
	Loose scrubhead switch wires.	Connect wires.
	Loose connection of plug at actuator.	Connect.
Scrubhead motors will not turn.	Defective actuator.	Replace.
	Loose or defective microswitch at actuator bellcrank.	Replace or tighten.
	Defective contactor.	Replace.
	Fuse blown.	Replace.
Side Scrub Option will not shift.	Loose plug at scrubhead motor. (Check all.)	Re-seat plug.
	Loose or defective switch on console.	Replace or connect.
Side Scrub Option will not lower.	Loose or defective actuator (under floor pan).	Replace or connect.
	Loose or defective switch on console.	Replace or connect.
Side Scrub Option will not lower.	Loose or defective actuator (under machine).	Replace or connect.
	Fuse blown.	Replace.



**SQUEEGEE PROBLEMS**

PROBLEM	CAUSE	SOLUTION
Squeegee will not lower.	Fuse blown.  Loose or defective squeegee switch (on console).  Loose wire(s) (#32, 33, 34 & 35) at foot pedal.  Foot pedal switches need adjustment.  Loose or defective switches beneath squeegee actuator.  Loose or defective control box contactors (wires 36, 37, 38 & 39).	Replace.  Replace or connect.  Connect.  Re-adjust cams.  Replace or connect.  Replace or connect.
Squeegee will not raise in reverse.	Foot pedal switches need adjustment.  Loose or defective switches beneath squeegee actuator.	Re-adjust cams.  Replace or connect.

## HYDRAULIC SYSTEM PROBLEMS

PROBLEM	CAUSE	SOLUTION
Hopper lift cylinder failure.	Line to cylinder leaking.	Tighten fittings or replace hose.
	Piston seals leaking.	Replace seals.
	Bent piston rod.	Replace rod.
Hydraulic control valve failure.	Misaligned control linkage.	Align.
	Foreign matter in spool bore.	Remove spool and clean bore.
	Valve seals leaking.	Replace seals.
	O-rings leaking.	Replace O-rings.
Hydraulic gear pump failure.	Pump leaking.	Replace seals.
	Gears worn or scored.	Rebuild pump.
	Relief valve stuck.	Clean or replace (at control valve).
	Hydraulic fluid supply low.	Check and fill.
	Incorrect hydraulic fluid (oil).	Use recommended viscosity oil.
	Damage due to entry of air into hydraulic system	Maintain correct hydraulic fluid level in reservoir. Keep suction hose fittings tight.

## HYDRAULIC SYSTEM PROBLEMS (CONT.)

PROBLEM	CAUSE	SOLUTION
Hydraulic variable displacement pump failure.	Pump leaking	Replace seals.
	Relief valve(s) stuck.	Clean or replace relief valve(s) at pump.
	Drive coupling malfunction.	Replace defective gears.
	Control linkage out of adjustment.	Check to see if linkage is binding unfastened.
	Charge pump gears worn or scored.	Replace defective gears.
Hydraulic system noisy.	Damage due to entry of air into hydraulic system.	Maintain correct hydraulic fluid level in reservoir. Keep suction hose fittings tight.
	Air in system.	Check fluid level in reservoir; check for loose connections or leaks.
	Loose suction line.	Tighten fittings.
	Clogged section filter or pump inlet line.	Replace filter, clear line; change fluid in reservoir if dirty and flush system.
	Internal pump or motor damage.	Inspect and repair.



## INDEX

Adjustment, Hopper .....	76
Adjustment, Hopper Vacuum .....	77
Adjustment, Main Broom Height .....	62
Adjustment, Main Broom Taper .....	63
Adjustment, Miscellaneous .....	83
Adjustment, Parking Brake Rod Length .....	81
Adjustment, Scrubhead .....	69
Adjustment, Scrubhead Gauge .....	69
Adjustment, Side Broom Height (Wear) .....	65
Adjustment, Side Broom Lift Cable .....	65
Adjustment, Squeegee Flare .....	70
Auto Squeegee Lift Mechanism, Mainten .....	72
Battery Cleaning .....	54
Battery Compartment, Specs .....	25
Battery Indicator, Operation .....	34
Battery Replacement .....	55
Brake, Parking, Maintenance .....	81
Brake, Parking, Operation .....	34
Brakes, Description .....	31
Broom, Main, Description .....	30
Broom, Main, Specs .....	24
Broom, Side, Adjustment Inspection .....	64
Broom, Side, Description .....	30
Broom, Side, Specs .....	24
Brooms, Maintenance .....	60
Brushes, Scrub, Operation .....	36
Brushes, Scrub, Specs .....	25
Cables, Maintenance .....	83
Capabilities, Description .....	30
Chain, Anti-Static .....	83
Chart, Planned Maintenance (PMC) .....	49
Controls, Clip/Seat, diagram .....	41
Controls, Lintel, diagram .....	42
Controls/ Accessories, Specs .....	25
Dimensions, Specs .....	25
Dipstick, Hydraulic .....	58
Directional Control Pedal, Operation .....	34
Drives, Specs .....	24
Electrical Schematic, TSS/65E .....	52
Electrical System, Description .....	28
Electrical System, Maintenance .....	54
Electrolyte Level, Checking .....	54
Emergency Shutoff, Operation .....	34
Filter, Dust Control, Cleaning of .....	75
Filter, Dust Control, Description .....	30

Filter, Dust Control, Removal of .....	74
Filter, Dust Control, Replacement .....	75
Flap, Replacement, Broom Door .....	61
Flaps, Broom Door Inspection .....	60
Frame, Specs .....	24
Fuse Replacement .....	55
Fuses, Description .....	28
Fuses, Maintenance .....	55
Fuses, Usage .....	28
Gasket Mount Assembly, Description .....	30
Grades, Operating on .....	41
Hinges, Maintenance .....	83
Hopper Controls, Operation .....	39
Hopper Dump Adjustments .....	76
Hopper Floor Clearance .....	76
Hopper Shut-off .....	See Gasket Mount
Hopper, Dumping .....	42
Hopper, Maintenance .....	73
Hopper, Specs .....	24
Hopper/Frame Seal Replacement .....	79
Hoppers, Description .....	31
Horn, Operation .....	34
Hour Meter, Operation .....	34
Hydraulic Filter, Changing the .....	59
Hydraulic Fluid Recommendation .....	58
Hydraulic Fluid Viscosity Specs .....	58
Hydraulic Reservoir, Filling the .....	58
Hydraulic Schematic .....	57
Hydraulics System, Description .....	29
Hydraulics System, Maintenance .....	58
Ignition, Operation .....	34
Installation, Squeegee Tool .....	72
Instruments, Specs .....	25
Introducing... ..	20
Introduction Section .....	19
Latches, Maintenance .....	83
Loading the Machine .....	43
Lubrication Points .....	56
Lubrication System, Description .....	29
Main Broom, Operation .....	35
Maintenance Section .....	45
Operating Procedures .....	40
Operator's Controls, diagram .....	41
Parking Brake, Maintenance .....	81
Parking Brake, Operation .....	34
Planned Maintenance Chart (PMC) .....	49
PMC, Brooms .....	49
PMC, Brushes, Scrub .....	51

PMC, Electrical .....	49
PMC, Hopper .....	50
PMC, Hydraulic.....	49
PMC, Impeller (TSS Only) .....	51
PMC, Miscellaneous .....	51
PMC, Parking Brake .....	50
PMC, Scrub Components .....	51
PMC, Steering .....	50
PMC, Sweeping Components .....	49
PMC, Tanks .....	50
PMC, Tires .....	51
PMC, Water Pick-Up Components .....	51
Pre-Operation Checks .....	40
Pushing or Towing the Machine .....	43
Recovery Tank, Cleaning the .....	38
Recovery Tank, Draining the .....	37
Recovery Tank, Specs .....	25
Removal, Broom, Side.....	67
Removal, Filter, Dust Control .....	74
Removal, Hopper .....	73
Removal, Scrub Brush.....	68
Removal, Squeegee Tool.....	71
Replacement, Broom, Main .....	66
Replacement, Broom, Side.....	67
Replacement, Filter, Dust Control .....	75
Replacement, Hopper .....	74
Replacement, Hopper Flap.....	78
Replacement, Scrub Brush.....	68
Replacement, Seal, Hopper .....	79
Replacement, Squeegee.....	71
Replacement, Squeegee, Inner .....	72
Safety Decals .....	13
Safety Section .....	11
Safety Symbols .....	12
Safety, Basic PowerBoss .....	15
Schematic, Electrical, TSS/65E .....	52
Schematic, Hydraulic .....	57
Scrub Brushes, Operation .....	36
Scrub Components, Maintenance.....	68
Scrub Path.....	24
Scrubbing Brushes, Specs .....	25
Scrubbing Controls, Operation.....	36
Scrubbing Coverage .....	25
Scrubbing, Double .....	37
Shaker Button, Filter, Operation.....	39
Shaker, Filter, Description .....	30
Side Broom, Operation .....	35
Skirts, Description .....	30

Slowing & Stopping ..... 41

Solution Tank, Specs ..... 25

Special Features ..... 21

Specifications Section ..... 23

Specifications, TSS/65E ..... 24

Speed, Adjusting Machine ..... 59

Squeegee Assembly, Specs ..... 25

Squeegee, Specs ..... 25

Starting the Machine ..... 40

Steering, Description ..... 31

Steering, Maintenance ..... 80

Steering, Specs ..... 24

Sweep Components, Description ..... 30

Sweep Components, Maintenance ..... 60

Sweep Coverage ..... 24

Sweep Path ..... 24

Sweeping Brooms, Specs ..... 24

Sweeping Controls, Operation ..... 35

Sweeping, Operation ..... 41

Tank, Recovery, Cleaning the ..... 38

Tank, Recovery, Draining the ..... 37

Tank, Recovery, Specs ..... 25

Tank, Solution, Filling ..... 36

Tank, Solution, Specs ..... 25

Test, Main Broom Height Adjustment ..... 61

Tires, Changing ..... 82

Tires, Description ..... 31

Tires, Maintenance ..... 82

Tires, Specs ..... 25

Transporting the Machine ..... 43

Troubleshooting Section ..... 85

TSS/65E Features ..... 8

Turning Radius, Specs ..... 24

Vacuum Pick-Up, Specs ..... 25

Vacuum System, Description ..... 30

Vacuum System, Specs ..... 24

Viscosity, Hydraulic Fluid ..... 58

Warranty Statement ..... 9

Water Pick-up Components, Maintenance ..... 68

Weight, Specs ..... 25

What You Will Find in This Manual ..... 7